



AN OSRAM BUSINESS

A.LEDA B-EYE K10 EASY

C61415

A.LEDA B-EYE K10

C61419

A.LEDA B-EYE K20

C61420

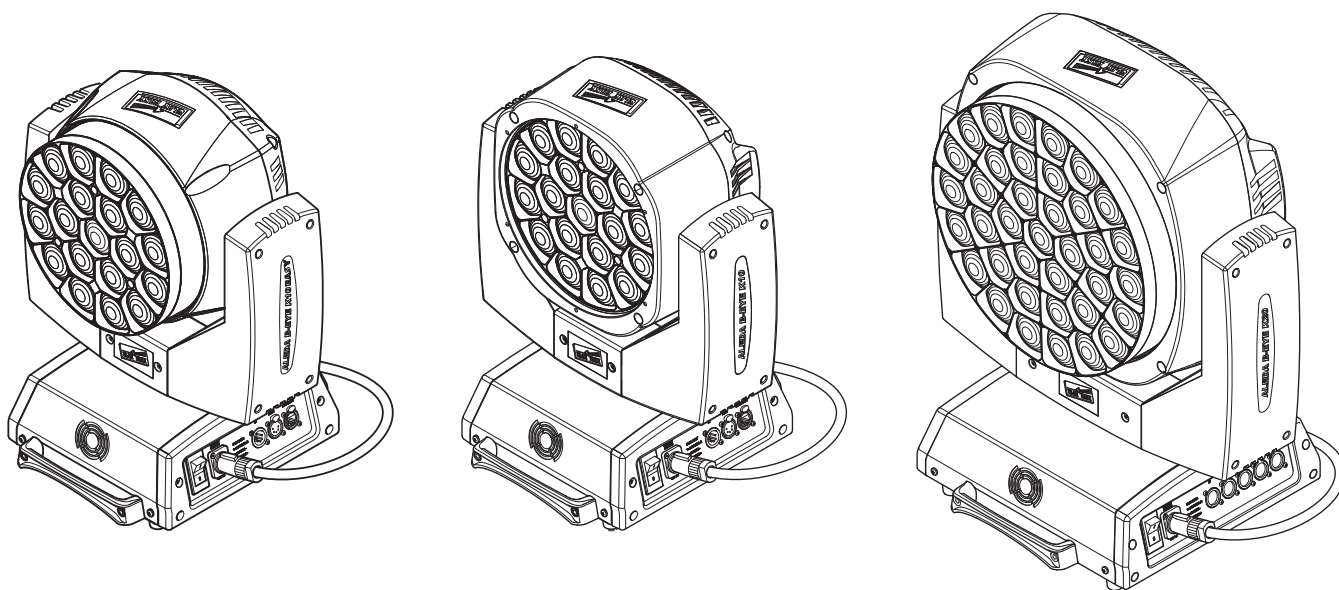
INSTRUCTION MANUAL**INDEX**

Page	Contents
2	Safety Information EN
4	Informazioni di sicurezza IT
6	Consignes de sécurité FR
8	Informationen zur Sicherheit DE
10	Informaciones de seguridad ES
12	Unpacking and preparation
13	Installation and start-up
14	Control panel
16	Menu setting
27	Maintenance
28	Cause and solution of problems
29	Technical information
30	Channel functions

Congratulations on choosing a Clay Paky product!

We thank you for your custom.

Please note that this product, as all the others in the rich Clay Paky range, has been designed and made with total quality to ensure excellent performance and best meet your expectations and requirements.

Carefully read this instruction manual in its entirety and keep it safe for future reference. It is essential to know the information and comply with the instructions given in this manual to ensure the fitting is installed, used and serviced correctly and safely.

CLAY PAKY S.p.A. disclaims all liability for damage to the fitting or to other property or persons deriving from installation, use and maintenance that have not been carried out in conformity with this instruction manual, which must always accompany the fitting.

CLAY PAKY S.p.A. reserves the right to modify the characteristics stated in this instruction manual at any time and without prior notice.

LED  0.2m

t_a 40°C

IP20



t_c 90°C



Risk Group 2
According to
EN 62471



• Installation

Make sure all parts for fixing the projector are in a good state of repair.

Make sure the point of anchorage is stable before positioning the projector.

The safety chain must be properly hooked onto the fitting and secured to the framework, so that, if the primary support system fails, the fitting falls as little as possible.

If the safety chain gets used, it needs to be replaced with a genuine spare.

• Minimum distance of illuminated objects

The projector needs to be positioned so that the objects hit by the beam of light are at least 0.20 metres (8") from the lens of the projector.

• Minimum distance from flammable materials

The projector must be positioned so that any flammable materials are at least 0.20 metres (8") from every point on the surface of the fitting.

• Maximum ambient temperature

Do not operate the fixture if the ambient temperature (T_a) exceeds 40° C (104° F).

• IP20 protection rating

The fitting is protected against penetration by solid bodies of over 12mm (0.47") in diameter (first digit 2), but not against dripping water, rain, splashes or jets of water (second digit 0).

• Protection against electrical shock

Connection must be made to a power supply system fitted with efficient earthing (**Class I** appliance according to standard EN 60598-1). It is, moreover, recommended to protect the supply lines of the projectors from indirect contact and/or shorting to earth by using appropriately sized residual current devices.

• Connection to mains supply

Connection to the electricity mains must be carried out by a qualified electrical installer. Check that the mains frequency and voltage correspond to those for which the projector is designed as given on the electrical data label. This label also gives the input power to which you need to refer to evaluate the maximum number of fittings to connect to the electricity line, in order to avoid overloading. A.leda B-EYEK20: the user must determine, in consultation with the supply authority, that the equipment is connected only to a supply with a maximum permissible system impedance Z_{max} , at the interface point of the user's supply, equal to 0.29 Ω or less.

• Temperature of the external surface

The maximum temperature that can be reached on the external surface of the fitting, in a thermally steady state, is 90°C (194°F).

• Maintenance

Before starting any maintenance work or cleaning the projector, cut off power from the mains supply.

• Light collimation system

This product contains internal light collimation system. Avoid intense light from any angle.

• Photobiological Safety

CAUTION. Possibly hazardous optical radiation emitted from this product. Do not stare at operating lamp. May be harmful to the eyes.

This product is intended for the following areas of application:

studios, stages, theaters, exhibitions, trade fairs, events, theme parks, entertainment venues, architectural lighting and similar

Not suitable for household illumination

Not for residential use



• **Battery**

This product contains a rechargeable lead-acid or lithium iron tetraphosphate battery. To preserve the environment, please dispose the battery at the end of its life according to the regulation in force.



• **Disposing**

This product is supplied in compliance with European Directive 2012/19/EU - Waste Electrical and Electronic Equipment (WEEE). To preserve the environment please dispose/recycle this product at the end of its life according to the local regulation.



The products to which this manual refers comply with the European Directives pursuant to:

- 2006/95/EC - Safety of electrical equipment supplied at low voltage (LVD)
- 2004/108/EC - Electromagnetic Compatibility (EMC)
- 2011/65/EU - Restriction of the use of certain hazardous substances (RoHS)
- 2009/125/EC - EcoDesign requirements for Energy-related Products (ErP)

LED  0,2m

t_a 40°C

IP20



t_c 90°C



Gruppo di rischio 2
Secondo la norma
EN 62471



• Installazione

Assicurarsi che tutte le parti per il fissaggio del proiettore siano in buona condizione.

Assicurarsi della stabilità del punto di ancoraggio prima di posizionare il proiettore.

La fune di sicurezza, debitamente agganciata all'apparecchio e fissata alla struttura di sostegno, deve essere installata in modo che, in caso di cedimento del sistema di supporto primario, si abbia la minor caduta possibile dell'apparecchio. Dopo un eventuale intervento la fune di sicurezza deve essere sostituita con il ricambio originale.

• Distanza minima degli oggetti illuminati

Il proiettore deve essere posizionato in modo tale che gli oggetti colpiti dal fascio luminoso siano distanti almeno 0,20 metri dall'obiettivo del proiettore stesso.

• Distanza minima dei materiali infiammabili

Il proiettore deve essere posizionato in modo tale che i materiali infiammabili siano distanti almeno 0,20 metri da ogni punto della superficie dell'apparecchio.

• Superficie di montaggio

È consentito il montaggio dell'apparecchio su superfici normalmente infiammabili.

• Massima temperatura ambiente

Non utilizzare il proiettore se la temperatura ambiente (T_a) supera i 40°C.

• Grado di protezione IP20

L'apparecchio è protetto contro la penetrazione di corpi solidi di dimensione superiore a 12mm (prima cifra 2), mentre teme lo stillicidio, la pioggia, gli spruzzi e i getti d'acqua (seconda cifra 0).

• Protezione contro la scossa elettrica

È obbligatorio effettuare il collegamento ad un impianto di alimentazione dotato di un'efficiente messa a terra (apparecchio di **Classe I** secondo la norma EN 60598-1).

Si raccomanda, inoltre, di proteggere le linee di alimentazione dei proiettori dai contatti indiretti e/o cortocircuiti verso massa tramite l'uso di interruttori differenziali opportunamente dimensionati.

• Collegamento alla rete di alimentazione

Le operazioni di collegamento alla rete di distribuzione dell'energia elettrica devono essere effettuate da un installatore elettrico qualificato. Verificare che frequenza e tensione della rete corrispondano alla frequenza ed alla tensione per cui il proiettore è predisposto ed indicate sulla targhetta dei dati elettrici. Sulla medesima targhetta è pure indicata la potenza assorbita. Fare riferimento a quest'ultima per valutare il numero massimo di apparecchi da collegare alla linea elettrica, al fine di evitare sovraccarichi.

• Temperatura della superficie esterna

La temperatura massima raggiungibile sulla superficie esterna dell'apparecchio, in condizioni di regime termico, è di 90°C.

• Manutenzione

Prima di iniziare qualsiasi operazione di manutenzione o pulizia sul proiettore togliere la tensione dalla rete di alimentazione.

• Sistema di collimazione di luce

Questo prodotto contiene un sistema interno di collimazione di luce. Evitare l'ingresso di luce intensa da qualsiasi angolazione.

• Sicurezza fotobiologica

ATTENZIONE: Possibile radiazione ottica rischiosa emessa da questo prodotto.

Non fissare la lampada in funzione. Può essere pericoloso per gli occhi.

Il prodotto è concepito per essere utilizzato nei seguenti ambiti:

studi, palchi, teatri, esposizioni, fiere, eventi, parchi a tema, locali di intrattenimento, illuminazione architettonica e simili.

Non adatto all'illuminazione domestica

Non per uso residenziale



• **Batteria**

Questo prodotto contiene una batteria ricaricabile piombo-acido o Litio Ferro Tetrafosfato. A tutela dell'ambiente si prega di smaltire la batteria a fine vita in conformità alla normativa vigente.



Smaltimento

Questo dispositivo è conforme alla Direttiva Europea 2012/19/UE - Rifiuti di apparecchiature elettriche ed elettroniche (RAEE). Nel rispetto dell'ambiente, smaltire/riciclare il prodotto al termine del suo ciclo di vita secondo le disposizioni di legge locali.to the local regulation.



I prodotti a cui questo manuale si riferisce sono conformi alle Direttive Europee di cui sono oggetto:

- 2006/95/CE - Sicurezza delle apparecchiature alimentate in Bassa Tensione (LVD)
- 2004/108/CE - Compatibilità Elettromagnetica (EMC)
- 2011/65/UE - Restrizione d'uso di determinate sostanze pericolose (RoHS)
- 2009/125/CE - Specifiche per la progettazione ecocompatibile dei prodotti connessi all'energia (ErP)

LED  0,2...m

t_a 40°C

IP20



t_c 90°C



Classe de dangerosité 2
Selon la norme
EN 62471



• Installation

S'assurer que toutes les pièces pour la fixation du projecteur sont en bon état.

S'assurer de la stabilité du point d'ancrage avant de positionner le projecteur.

Le câble de sécurité, à fixer correctement à l'appareil et à la structure de support, doit être installé de façon à ce que, en cas de rupture du système de support principal, la chute de l'appareil soit la plus limitée possible.

Après une éventuelle intervention du câble de sécurité suite à une chute, il faut le remplacer par une pièce de rechange d'origine.

• Distance minimum des objets éclairés

Le projecteur doit être positionné de façon à ce que les objets éclairés par le faisceau lumineux soient à une distance d'au moins 0,20 mètres de l'objectif du projecteur.

• Distance minimum des substances inflammables

Le projecteur doit être positionné de façon à ce qu'il y ait une distance d'au moins 0,20 mètre entre toute substance inflammable et tout point de sa surface.

• Température ambiante maximum

Ne pas utiliser le projecteur quand la température ambiante (T_a) dépasse 40°C.

• Degré de protection IP20

L'appareil est protégé contre la pénétration de corps solides de dimension supérieure à 12 mm (premier chiffre 2), tandis qu'il craint les gouttes d'eau, la pluie et les projections d'eau (deuxième chiffre 0).

• Protection contre l'électrisation

L'appareil doit obligatoirement être branché à une installation d'alimentation équipée d'une mise à la terre efficace (appareil de **Classe I** selon la norme EN 60598-1).

Nous recommandons également de protéger les lignes d'alimentation des projecteurs contre les contacts indirects et/ou les courts-circuits vers la masse en utilisant des interrupteurs différentiels de sensibilité adéquate.

• Branchement au réseau d'alimentation

Les opérations de branchement au réseau de distribution de l'énergie électrique doivent être exécutées par un installateur électrique qualifié.

Contrôler que la fréquence et la tension de réseau correspondent à la fréquence et à la tension pour lesquelles le projecteur est prévu ; ces données sont indiquées sur la plaquette des données électriques. Cette même plaquette reporte également la puissance absorbée. Afin d'éviter des surcharges, se référer à celle-ci pour évaluer le nombre maximum d'appareils à brancher à la ligne électrique.

• Température de la surface extérieure

La température maximum qui peut être atteinte sur la surface extérieure de l'appareil, en conditions de régime thermique, est de 90°C.

• Entretien

Avant de procéder à toute opération d'entretien ou de nettoyage sur le projecteur, couper la tension d'alimentation.

• Système de collimation de la lumière

Ce produit contient un système de collimation de la lumière. Éviter qu'une lumière intense n'entre d'un quelconque angle de vue.

• Sécurité photobiologique

ATTENTION : Possible radiation optique émise par ce produit.

Ne pas fixer la lampe lorsqu'elle est allumée. Peut être dangereux pour les yeux.

Le produit est conçu pour être utilisé dans les milieux suivants :

studios, scènes, théâtres, expositions, salons, événements, parcs à thème, lieux de divertissement, éclairage architectural et similaires

Non adapté à l'éclairage domestique

Non indiqué pour un utilisation résidentiel



• **Batteria**

Ce produit contient une batterie rechargeable au plomb-acide ou tétraphosphate de fer au lithium. Une fois la batterie arrivée à la fin de sa durée de vie, procéder à son élimination conformément à la norme en vigueur de manière à éviter toute pollution.

Élimination

Ce dispositif est conforme à la Directive Européenne 2012/19/UE – Déchets d'équipements électriques et électroniques (DEEE). Dans le respect de l'environnement, écouler/recycler le produit à la fin de son cycle de vie selon les dispositions légales locales.

The products to which this manual refers comply with the European Directives pursuant to:

- 2006/95/EC - Safety of electrical equipment supplied at low voltage (LVD)
- 2004/108/EC - Electromagnetic Compatibility (EMC)
- 2011/65/EU - Restriction of the use of certain hazardous substances (RoHS)
- 2009/125/EC - EcoDesign requirements for Energy-related Products (ErP)

LED  0,2m

t_a 40°C

IP20



t_c 90°C



Gefahrenklasse 2
Gemäß Norm
EN 62471



• Installation

Sicherstellen, dass alle Teile für die Befestigung des Projektors in einwandfreiem Zustand sind.

Vor der Installation des Projektors die Stabilität der Verankerungsstelle überprüfen.

Das korrekt am Gerät eingehakte und an der Haltestruktur befestigte Sicherheitsseil muss so installiert werden, dass bei einem Nachgeben der Haupthalterung die Fallhöhe des Gerätes so gering wie möglich ist. Nach einem eventuellen Einsatz muss das Sicherheitsseil durch ein Originalersatzteil ersetzt werden.

• Mindestabstand zu beleuchteten Objekten

Der Projektor muss so installiert werden, dass der Abstand zwischen den vom Lichtstrahl beleuchteten Objekten und dem Objektiv des Projektors mindestens 0,20 Meter beträgt.

• Mindestabstand zu entzündbaren Materialien

Der Projektor muss so installiert werden, dass entzündbare Materialien mindestens 0,20 Meter von jedem Punkt der Geräteoberfläche entfernt sind.

• Max. Raumtemperatur

Den Projektor nicht verwenden, wenn die Raumtemperatur (RT) 40°C überschreitet.

• Schutzart IP20

Das Gerät ist gegen das Eindringen von festen Fremdkörpern mit Durchmesser über 12 mm (erste Kennziffer 2) geschützt, während es gegen Tropf-, Regen- und Spritzwasser sowie Wasserstrahlen (zweite Kennziffer 0) empfindlich ist.

• Schutz gegen Stromschlag

Es ist Pflicht, das Gerät an eine Stromversorgungsanlage anzuschließen, die mit einer leistungsfähigen Erdung ausgestattet ist (Gerät der **Klasse I** gemäß Richtlinie EN 60598-1).

Darüber hinaus wird empfohlen, die Zuleitungen der Projektoren mit korrekt bemessenen Fehlerstromschutzschaltern vor indirekten Kontakten und/oder Kurzschlüssen zu schützen.

• Netzanschluss

Der Anschluss an das Stromnetz muss von einem kompetenten Elektroinstallateur ausgeführt werden. Vergewissern Sie sich, dass Spannung und Frequenz der Netzversorgung mit den Werten übereinstimmen, für die der Projektor ausgelegt ist und die auf dem Typenschild angegeben sind. Ebenfalls auf dem Typenschild ist die Leistungsaufnahme angegeben. Um zu beurteilen, wie viele Geräte maximal an die Stromleitung angeschlossen werden können, ist auf diese Angaben Bezug zu nehmen, damit Überlastungen vermieden werden.

• Temperatur der Außenfläche

Die Außenfläche des Geräts kann im Wärmebetrieb eine Höchsttemperatur von 90°C erreichen.

• Wartung

Vor Beginn von Wartungs- oder Reinigungsarbeiten am Projektor stets die Stromversorgung abschalten.

• System zur Lichtkollimation

Dieses Produkt enthält ein internes System zur Kollimation des Lichts. Den Eintritt von starkem Licht aus jedem Einfallswinkel vermeiden.

• Photobiologische Sicherheit

ACHTUNG: Mögliche riskante optische Strahlung wird von diesem Produkt abgegeben.

Nicht die Lampe fixieren, wenn sie in Betrieb ist. Kann für die Augen gefährlich sein.

Das Produkt wurde für die Verwendung in den folgenden Bereichen entwickelt:

Studios, Bühnen, Theater, Ausstellungen, Messen, Veranstaltungen, Themenparks, Unterhaltungslokale, Architekturbeleuchtung oder ähnliches

Nicht für Haushaltsbeleuchtung geeignet

Nicht für den häuslichen Gebrauch



• **Batterie**

Dieses Produkt enthält eine wiederaufladbare Blei-Säure-Batterie oder Lithium-Eisen-tetraphosphat. Zum Schutz der Umwelt bitten wir Sie, diese Batterie, nachdem sie verbraucht ist, gemäß den geltenden Vorschriften zu entsorgen.



Entsorgung

Diese Vorrichtung entspricht der Europäischen Richtlinie 2012/19/UE - Abfall von elektrischen und elektronischen Gerätschaften (RAEE). Das Produkt am Ende seines Lebenszyklus unter Berücksichtigung der Umwelt nach den lokalen Gesetzesvorschriften entsorgen/recyclen.



The products to which this manual refers comply with the European Directives pursuant to:

- 2006/95/EC - Safety of electrical equipment supplied at low voltage (LVD)
- 2004/108/EC - Electromagnetic Compatibility (EMC)
- 2011/65/EU - Restriction of the use of certain hazardous substances (RoHS)
- 2009/125/EC - EcoDesign requirements for Energy-related Products (ErP)

LED  0.2m

t_a 40°C

IP20



t_c 90°C



Clase de
peligrosidad 2
Según la norma
EN 62471



• Instalación

Asegúrese de que todos los elementos de fijación del proyector estén en buenas condiciones.

Controle la estabilidad del punto de anclaje antes de instalar el proyector.

La cuerda de seguridad, correctamente enganchada al aparato y fijada a la estructura de soporte, debe colocarse de modo que, si el soporte principal cede, el aparato sufra la menor caída posible. En caso de desgaste de la cuerda de seguridad, sustitúyala por el recambio original.

• Distancia mínima de los objetos iluminados

El proyector debe ser posicionado de modo tal que los objetos tocados por el haz luminoso tengan una distancia de al menos 0,20 metros del objetivo del mismo proyector.

• Distancia mínima de los materiales inflamables

El proyector debe ser posicionado de modo tal que los materiales inflamables tengan una distancia de al menos 0,20 metros de cada punto de la superficie del aparato.

• Máxima temperatura ambiente

No utilice el proyector si la temperatura ambiente (t_a) supera los 40°C.

• Grado de protección IP20

El aparato está protegido contra la penetración de cuerpos sólidos de dimensiones superiores a 12 mm (primer dígito 2), pero no contra el goteo, la lluvia, las salpicaduras y los chorros de agua (segundo dígito 0).

• Protección contra descargas eléctricas

Es obligatorio efectuar la conexión a una instalación de alimentación dotada de una eficiente puesta a tierra (aparato de **Clase I** según la norma EN 60598-1).

Además, se recomienda proteger las líneas de alimentación de los proyectores de los contactos indirectos y/o cortocircuitos hacia masa, mediante el uso de interruptores diferenciales dimensionados oportunamente.

• Conexión a la red de alimentación

Las operaciones de conexión a la red de distribución de la energía eléctrica deben ser efectuadas por un instalador eléctrico cualificado. Constate que los valores de frecuencia y tensión de la red sean iguales a los que figuran en la placa de los datos eléctricos del proyector. En la misma placa está indicada la potencia absorbida. Hacer referencia a esta última para valorar el número máximo de aparatos que conectar a la línea eléctrica, con el fin de evitar sobrecargas.

• Temperatura de la superficie externa

La temperatura máxima que puede alcanzar la superficie externa del aparato, en condiciones de régimen térmico, es de 90°C.

• Mantenimiento

Antes de iniciar cualquier operación de mantenimiento o limpieza del proyector desconecte el aparato de la alimentación eléctrica.

• Sistema de colimación de luz.

Este producto contiene un sistema interno de colimación de luz.

Evitar la difusión de luz intensa desde cualquier angulación.

• Seguridad fotobiológica

ATENCIÓN: Posible radiación óptica arriesgada emitida por este producto.

No fije la lámpara en funcionamiento. Puede ser peligroso para los ojos.

El producto es concebido para ser utilizado en los siguientes ambientes:

estudios, palcos, teatros, exposiciones, ferias, eventos, parques temáticos locales de entretenimiento, iluminación de arquitecturas y similares

No es apropiado para la iluminación doméstica

No para uso residencial



• **Batería**

Este producto contiene una batería recargable plomo-ácido o de litio tetrafosfato Hierro. Para proteger el ambiente se ruega eliminar la batería conforme a la normativa vigente.



Eliminación

Este dispositivo es conforme a la Directiva Europea 2012/19/UE - Residuos de equipos eléctricos y electrónicos (RAEE). Con el fin de respetar el ambiente, eliminar/reciclar el producto al final de su ciclo de vida según las disposiciones de ley locales



The products to which this manual refers comply with the European Directives pursuant to:

- 2006/95/EC - Safety of electrical equipment supplied at low voltage (LVD)
- 2004/108/EC - Electromagnetic Compatibility (EMC)
- 2011/65/EU - Restriction of the use of certain hazardous substances (RoHS)
- 2009/125/EC - EcoDesign requirements for Energy-related Products (ErP)

UNPACKING AND PREPARATION

1

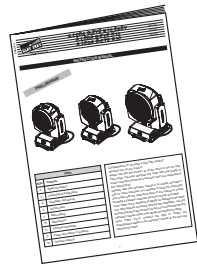

IST009/001

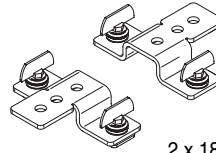

2 x 183102/805

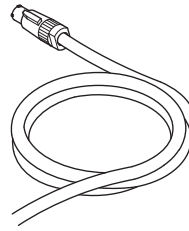

Packing contents - Fig. 1

2

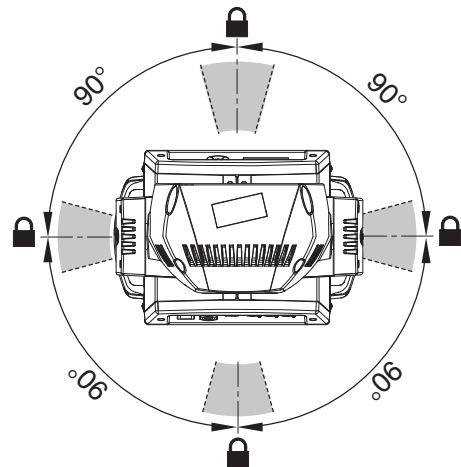
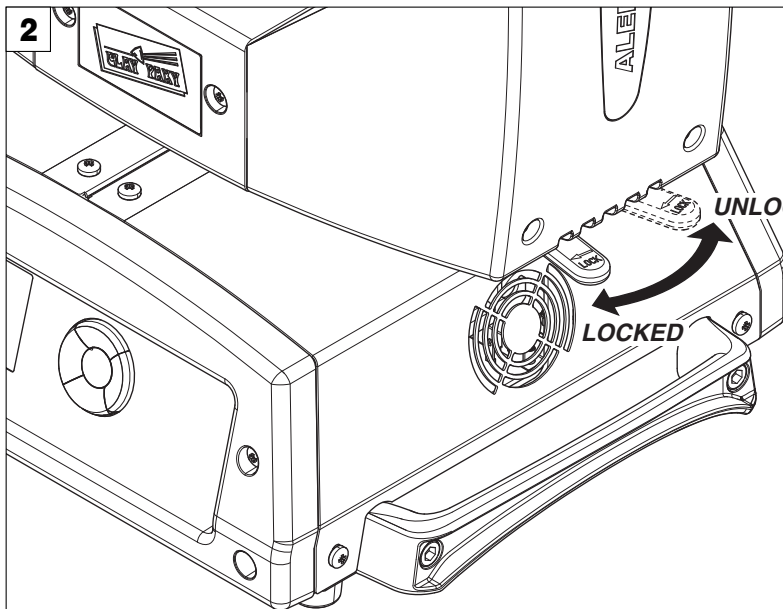

PAN Mechanism Lock and Release (every 90°) - Fig. 2

INSTALLATION AND START-UP

3

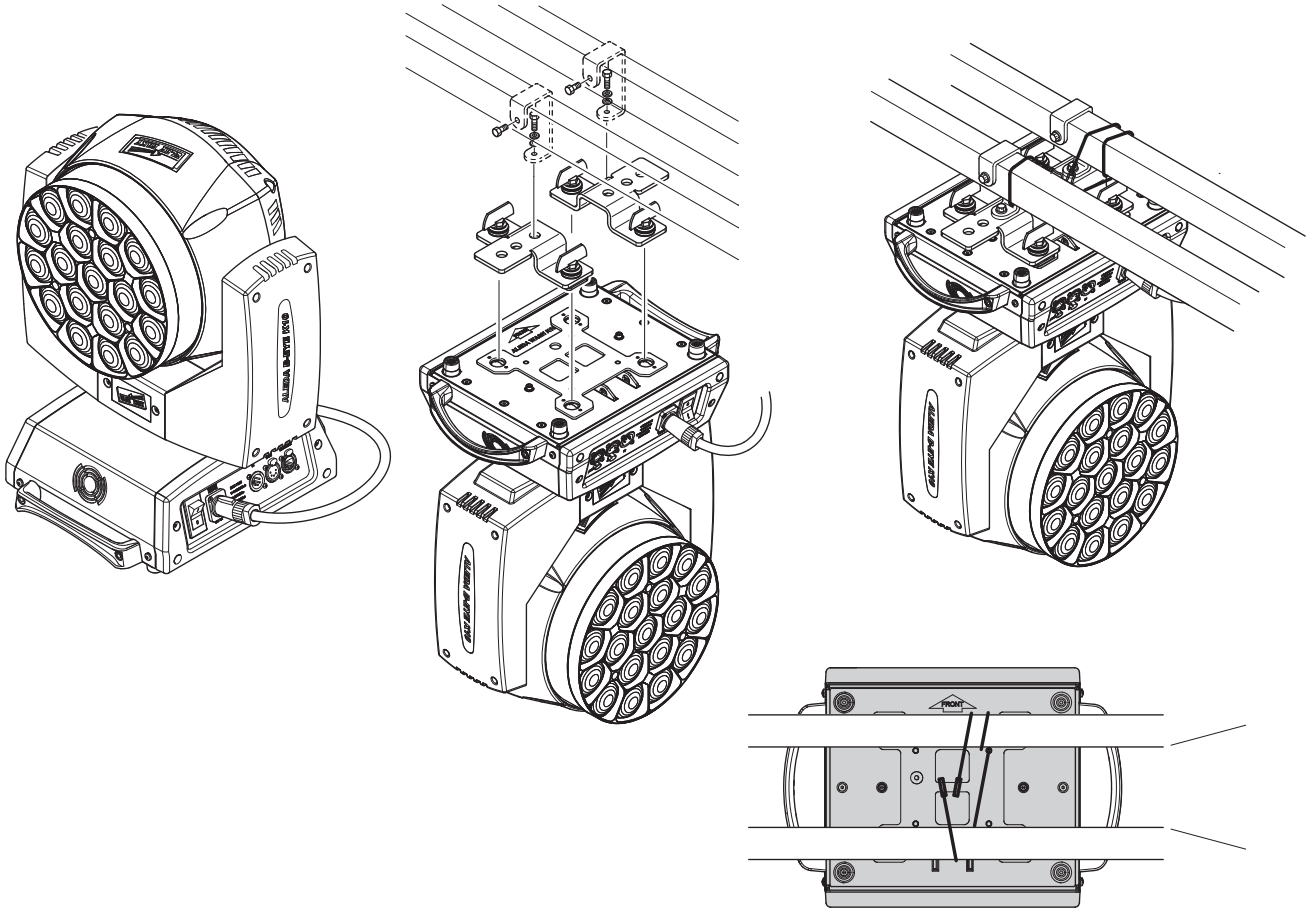

Installing the projector - Fig. 3

The projector can be installed on the floor resting on special rubber feet, on a truss or on the ceiling or wall.

WARNING: with the exception of when the projector is positioned on the floor, the safety cable must be fitted. (Cod. 105041/003 available on request). This must be securely fixed to the support structure of the projector and then connected to the fixing point at the centre of the base.

4

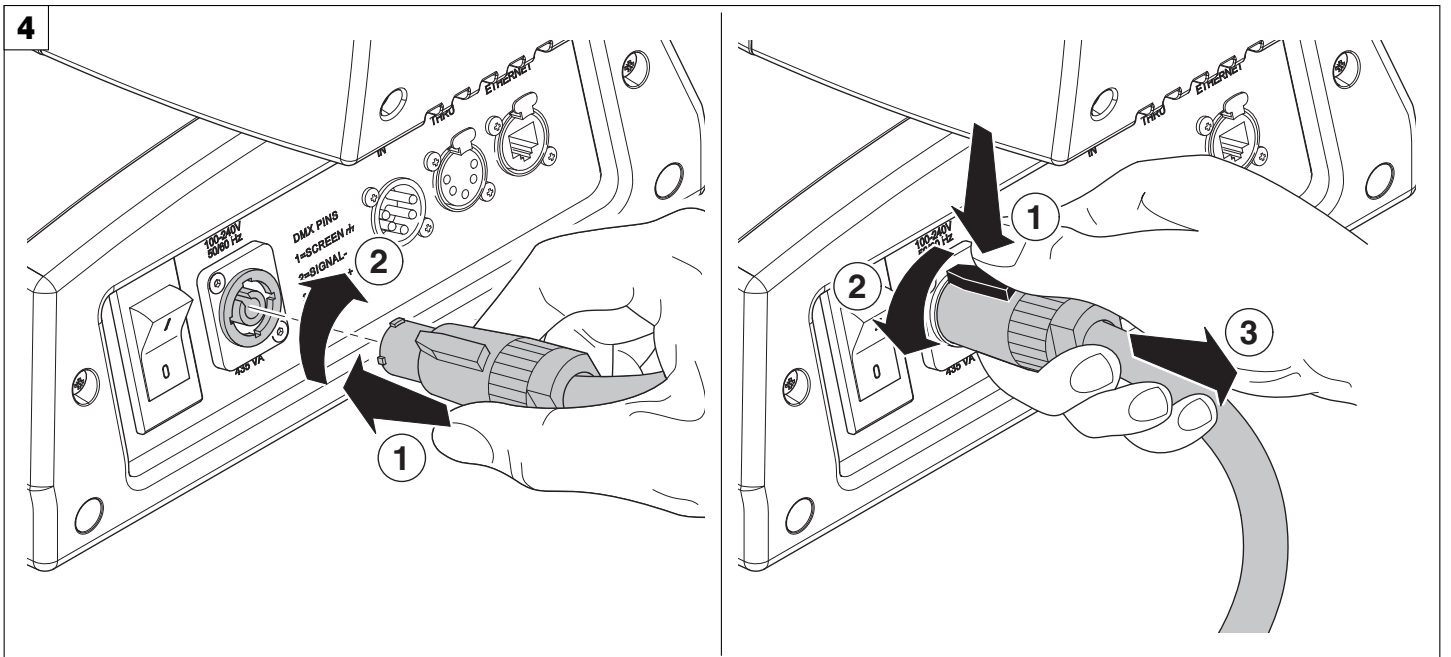

Connecting and disconnecting power cable - Fig. 4

CONTROL PANEL

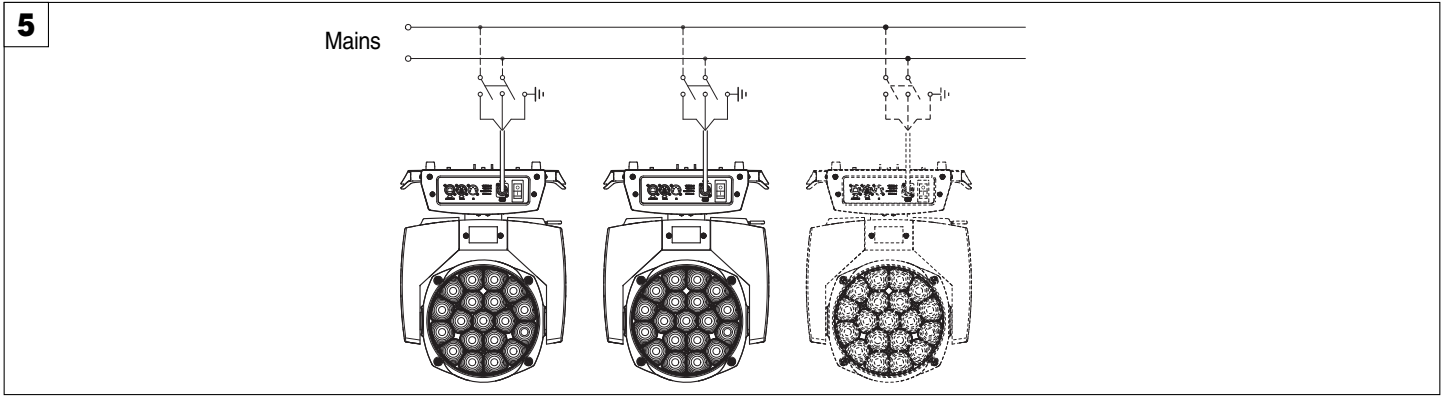

Connecting to the mains supply - Fig. 5

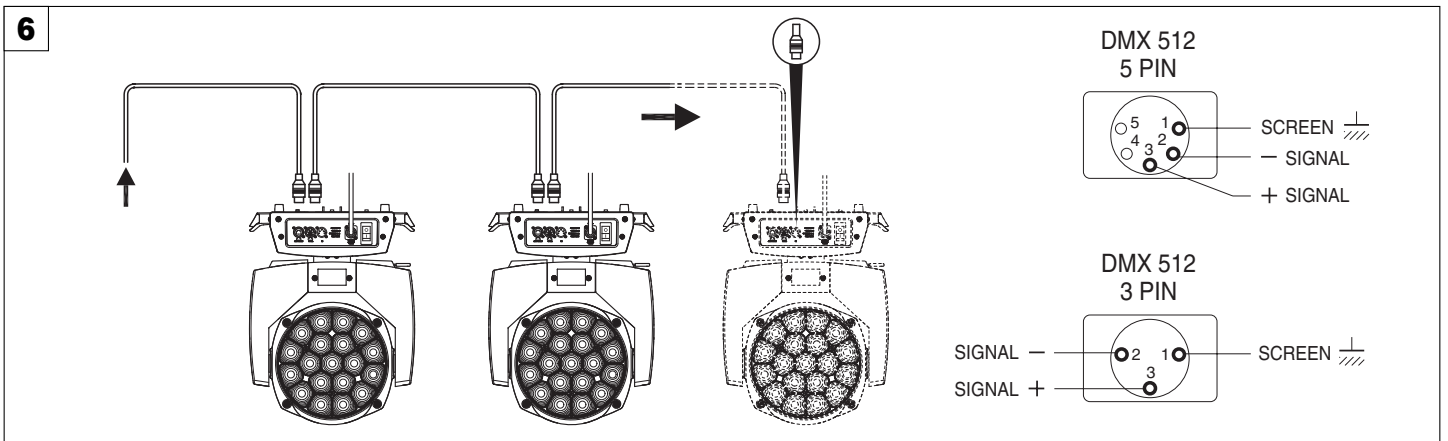

Connecting to the control signal line (DMX) - Fig. 6

Use a cable conforming to specifications EIA RS-485: 2-pole twisted, shielded, 120Ohm characteristic impedance, 22-24 AWG, low capacity. Do not use microphone cable or other cable with characteristics differing from those specified. The end connections must be made using XLR type 3 or 5-pin male/female connectors. A terminating plug must be inserted into the last projector with a resistance of 120Ohm (minimum 1/4 W) between terminals 2 and 3.

IMPORTANT: The wires must not make contact with each other or with the metal casing of the connectors. The casing itself must be connected to the shield braid and to pin 1 of the connectors.

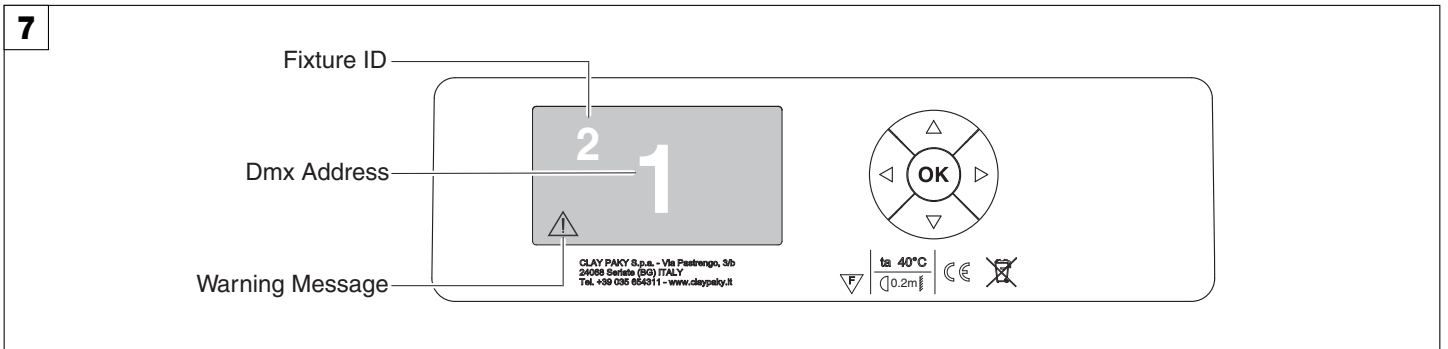

Switching on the projector - Fig. 7

Press the switch. The projector starts resetting the effects. At the same time, the following information scrolls on the display:

	Model A.leda B-EYE	Firmware Version X.X.X Date - Hour	xxx (Fixture ID) Dmx Address xxx	System errors E: W:
--	------------------------------	---	--	--

On conclusion of resetting in case of absence of the dmx signal, Pan and Tilt move to the "Home" position (Pan 50% - Tilt 50%). The control panel (Fig. 7) has a display and buttons for the complete programming and management of the projector menu. The display can be in one of two conditions: rest status and setting status. When it is in the rest status, the display shows the projector's DMX address and the Fixture ID address (if set). During menu setting status, after a wait time (about 30 seconds) without any key having been pressed, the display automatically returns to rest status. It should be noted that when this condition occurs, any possible value that has been modified but not yet confirmed with the **OK** key will be cancelled.

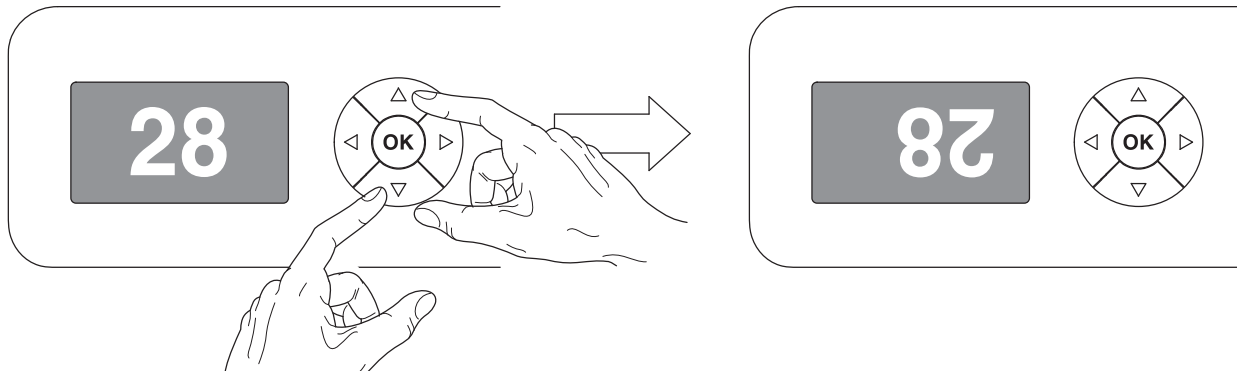

Reversal of the display - Fig. 8

To activate this function, press UP and DOWN keys simultaneously while the display is in the rest mode. This status will be memorised and maintained even for the next time it will be switched on. To return to the initial state, repeat the operation all over again.

Setting the projector starting address

On each projector, the starting address must be set for the control signal (addresses from 1 to 512).

The address can also be set with the projector switched off.

Setting the address: see pag. 11.

Setting the projector Fixture ID

On each projector, the Fixture ID address must be set for an easy identification of the fixtures in an installation (ID from 1 to 255).

The Fixture ID address can be set with the projector switched off.

Setting the Fixture ID: see pag. 11.

Functions of the buttons - Using the menu

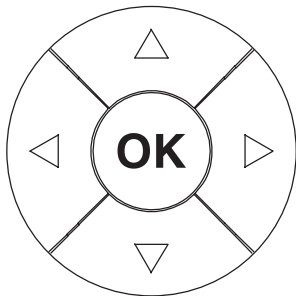

Confirms the displayed value, or activates the displayed function, or enters the successive menu.



DOWN

Decreases the value displayed (with auto-repetitions) or passes to the next item in the menu.



UP

Increases the value displayed (with auto-repetitions) or passes to the previous item in a menu.



LEFT

Return to the top level.



RIGHT

Commute from units, tens, hundreds, in the "Address", "Fixture ID" and "Calibration" menu.

USING THE MENU:

- 1) Press once – "Main Menu" appears on the display.
- 2) Use the UP and DOWN keys to select the menu to be used:
 - Setup (Setup Menu): To set the setting options.
 - Option (Option Menu): To set the operating options
 - Informations (Informations Menu): To read the counters, software version and other information.
 - Manual Control (Manual control Menu): To trigger the test and manual control functions.
 - Test (Test Menu): To check the proper functioning of effects
 - Advanced (Advanced Menu): Access to the "Advanced menu" is recommended for a trained technical personnel.

To enable the "Advanced" see pag. 15.
- 3) Press to display the first item in the selected menu.
- 4) Use the UP and DOWN keys to select the MENU items.

Setting addresses and options with the projector disconnected

The projector's DMX address, as well as other possible operating options, can also be set when the appliance is disconnected from the electricity supply. All that is needed is to press to momentarily activate the display and thus access the settings. Once the required operations have been carried out, the display will switch off again after a wait time of 30 seconds.

MENU SETTING

XXX = default value

Main Menu	Level 1	Level 2	Level 3	Choices / Values	
SET UP	Basic Engine	Mode		Standard Shape	
		Source		DMX Art-net	
		Universe		0 - 255	
		DMX Address		1 - 512	
	Pixels Engine	Mode		Disabled RGB RGBW	
		Source		DMX Art-net	
		Universe		0 - 255	
		DMX Address		1 - 512	
	Repeat on DMX	Enablement		Disabled Enabled on primary	
		Universe		0 - 255	
	Ethernet Interface	Control Protocol		Disabled Art-net on IP 2.x.x.x Art-net on IP 10.x.x.x Custom IP	
		Custom IP Address	IP address byte 1		0 - 255
			IP address byte 2		0 - 255
			IP address byte 3		0 - 255
			IP address byte 4		0 - 255
Custom IP Mask	IP mask byte 1		0 - 255		
	IP mask byte 2		0 - 255		
	IP mask byte 3		0 - 255		
	IP mask byte 4		0 - 255		
Fixture ID			0 - 255		

Main Menu	Level 1	Level 2	Level 3	Choices / Values	
OPTION	Pan / Tilt	Invert Pan		On / Off	
		Invert Tilt		On / Off	
		Swap Pan-Tilt		On / Off	
		Encoder Pan-Tilt		On / Off	
		P/T Homing mode		Standard Sequenced	
		Pan Home Def Pos		0 degree 90 degrees 180 degrees 270 degrees	
		Tilt Home Def Pos		0 % 12.5 % 25 % 50 % 75 % 87.5 % 100 %	
	Silent Mode			Standard Quiet	
	Fan Speed Mode			Auto Full	
	Display			On / Off	
	Special Functions	Pan/Tilt speed			Normal Fast
		Dimmer curve			Curve 1 Curve 2 Curve 3 Curve 4
		RGB Gamma			Gamma 1.0 Gamma 1.5 Gamma 2.0
		Halogen Mode			Halogen OFF Halogen Lamp 1 Halogen Lamp 2 Halogen Lamp 3 Halogen Lamp 4 Halogen Lamp 5
	Setting	Default Preset			Reset To Default Go Back
		User Preset 1			Load preset 1 Save to preset 1
		User Preset 2			Load preset 2 Save to preset 2
		User Preset 3			Load preset 3 Save to preset 3

Main Menu	Level 1	Level 2	Level 3	Choices / Values
INFORMATION	System Errors			Read / Reset
	Fixture Hours	Total Hours		Read
		Partial Hours		Read / Reset
	LED Energy Tot	Total Hours		Read
		Partial Hours		Read / Reset
	System Version	Aleda fw		Fw.rev.
		CPU board		Hw.rev.
		com.dev		Fw.rev.
		0:PT-3f		Fw.rev. / Hw.rev.
		1:Ld-k20		Fw.rev. / Hw.rev.
	Board Diagnostic	0:PT-3f		Status / Err%
		1:Ld-k20		Status / Err%
	DMX Monitor	Channels		<i>Value / Percentage</i>
	Fans Monitor	PwrSp		Speed (RPM)
		PwrSp		Speed (RPM)
		Head		Speed (RPM)
	Sensor Status	Pan		ON / OFF / n.a.
Tilt			ON / OFF / n.a.	
Zoom Rotation			ON / OFF / n.a.	
Zoom			ON / OFF / n.a.	
Network parameters	IP Address			
	IP Mask			
	MAC Address			
MANUAL CONTROL	Reset			Yes / No
	Channels			Value / Percentage
TEST	Pan / Tilt			
	Colour			
	Zoom			
	Rotation			
	All			
	Zoom Rotation Sensor Test			
ADVANCED	Access Code <u>1234</u>	Upload Firmware		Yes / No
		Setup Model		Yes / No
		Calibration	Channels	000 - 255
		LED calibration	LED Selection 01-37	Red 0-255 Green 0-255 Blue 0-255 White 0-255
			<i>Reset To Default LED Calibration</i>	

NOTE: On grey the default options

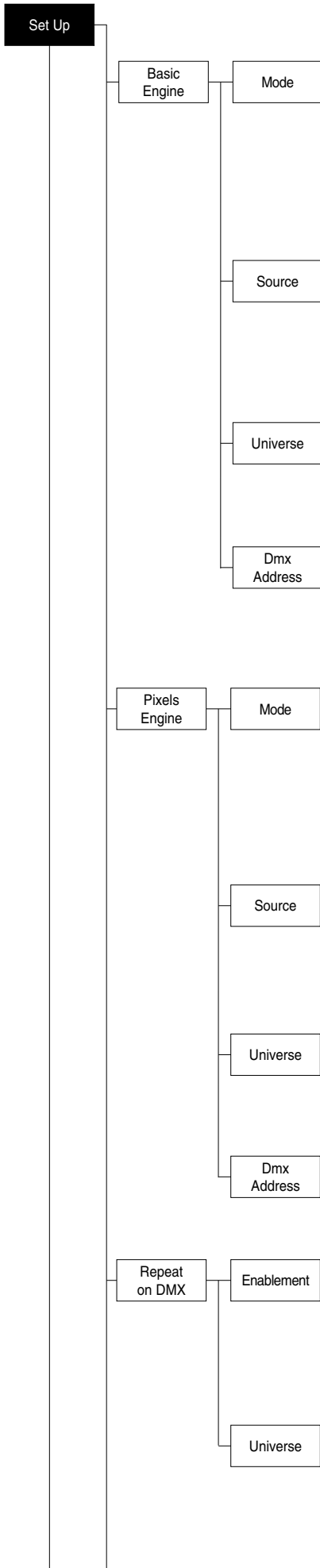

SET UP MENU

For greater programming ease using the DMX control unit and Media-server Art-net, channel mapping is divided into BASIC ENGINE and PIXEL ENGINE (see details in Channel Function).

BASIC ENGINE

Mode

This lets you select the projector operating mode for BASIC ENGINE, selecting one of the two available modes:

- **Standard** (see channel mapping in Channel Function)
- **Shape** (see channel mapping in Channel Function)

Source

It lets you assign the input source the projector receives signals from dedicated to BASIC ENGINE. One of the two available sources can be selected:

- **DMX**
- **Art-net**

Universe

It lets you set “DMX Universe” for BASIC ENGINE mode to assign values between 000 and 255 to a series of projectors (This option is valid only if Source= **Art-net**)

DMX Address

It lets you select the address (DMX Address) for the control signal by BASIC ENGINE. A DMX address between 001 and 512 can be selected.

NOTE: Without the DMX input signal, the displayed address (DMX Address) blinks.

PIXELS ENGINE (Function Channel to 103-105 bit, see pag. 25)

Mode

This lets you select the projector operating mode for PIXELS ENGINE, selecting one of the three available modes:

- **Disabled**
- **RGB** (see channel mapping in Channel Function)
- **RGBW** (see channel mapping in Channel Function)

Source

It lets you assign the input source the projector receives signals from dedicated to PIXELS ENGINE. One of the two available sources can be selected:

- **DMX**
- **Art-net**

Universe

It lets you set “DMX Universe” for PIXELS ENGINE mode to assign values between 000 and 255 to a series of projectors (This option is valid only if Source= **Art-net**)

DMX Address

It lets you select the address (DMX Address) for the control signal by PIXELS ENGINE. A DMX address between 001 and 512 can be selected.

REPEAT ON DMX

Enablement

It lets you enable/disable the transmission of the Ethernet protocol by DMX signal to all the connected projectors.

- **Disabled:** DMX transmission disabled.
- **Enabled on primary:** DMX transmission enabled.

Universe

It lets you set the “DMX Universe” to assign values between 000 and 255 to a series of projectors. In this case it refers to an Art-net input not read by the projector and re-transmitted to other projectors.

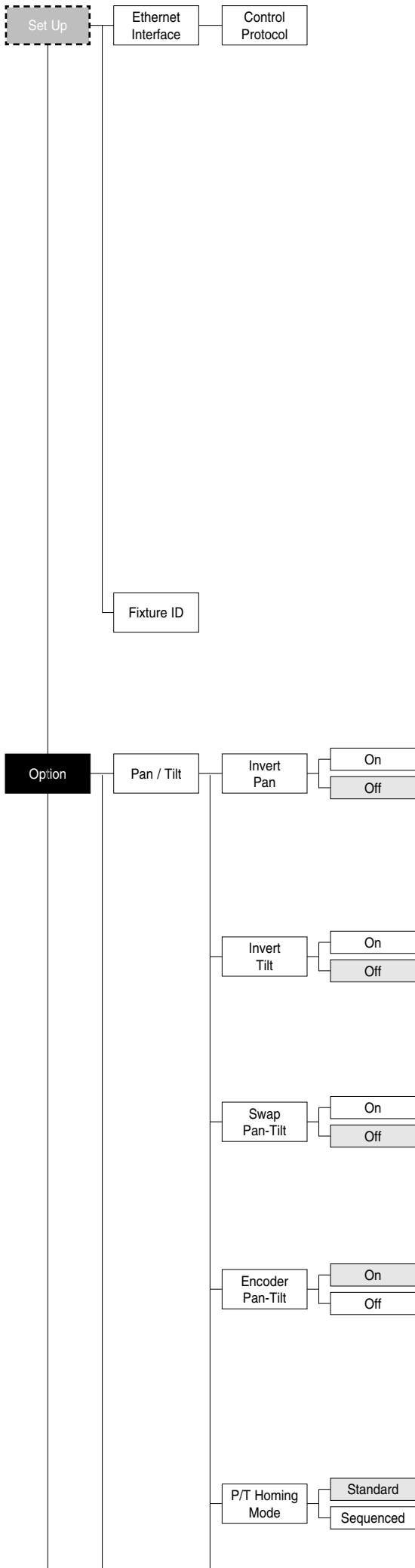

ETHERNET INTERFACE

It lets you set the Ethernet settings to be attributed to the projector.

Control Protocol

It lets you select the Art-net "Control Protocol" to be assigned according to the control unit used. The following options are available:

- Disabled
- Art-net on IP 2.x.x.x
- Art-net on IP 10.x.x.x
- Custom IP

If the Control Protocol option is set on Disabled, when an IP address (IP2, IP10 or IP Custom) is selected, the projector immediately initializes the IP address that was just selected.

If the Control Protocol option is enabled (IP2, IP10 or IP Custom) and a new one is selected that is different from the previous one, the projector must be restarted so that it will be correctly initialized.

Custom IP address

Allows you to set the **IP address** by the user default.

Custom IP mask

Allows you to set the **Subnet Mask** by the user default

FIXTURE ID

It lets you set the "Fixture ID" to be assigned to the projector. An "ID" between 000 and 255 can be assigned.

OPTIONS MENU

PAN / TILT

Invert pan

Used for reversing Pan movement.

- 1) Press **OK** - the current settings appear on the display (On or Off).
- 2) Use the UP **▲** and DOWN **▼** keys to enable (On) or disable (Off) PAN inversion.
- 3) Press **OK** to confirm the selection or LEFT **◀** to keep current settings.

Invert tilt

Used for reversing tilt movement.

- 1) Press **OK** - the current settings appear on the display (On or Off).
- 2) Use the UP **▲** and DOWN **▼** keys to enable (On) or disable (Off) Tilt inversion.
- 3) Press **OK** to confirm the selection or LEFT **◀** to keep current settings.

Swap Pan-Tilt

Used for swapping Pan and Tilt channels (as well as Pan fine and Tilt fine).

- 1) Press **OK** - the current settings appear on the display (On or Off).
- 2) Use the UP **▲** and DOWN **▼** keys to enable (On) or disable (Off) Pan and Tilt channel swap.
- 3) Press **OK** to confirm the selection or LEFT **◀** to keep current settings.

Encoder Pan-Tilt

Used for enabling the Pan / Tilt encoders.

- 1) Press **OK** - the current settings appear on the display (On or Off).
- 2) Use the UP **▲** and DOWN **▼** keys to enable (On) or disable (Off) Pan / Tilt encoders.
- 3) Press **OK** to confirm the selection or LEFT **◀** to keep current settings.

You can quickly disable the Pan and Tilt Encoder by simultaneously pressing the UP **▲ and DOWN **▼** keys in the "Main Menu".**

P/T Homing Mode

Lets you set the initial projector Reset mode.

- 1) Press **OK**, the current setting appears on the display.
- 2) Use the UP **▲** and DOWN **▼** keys to select one of the following settings:

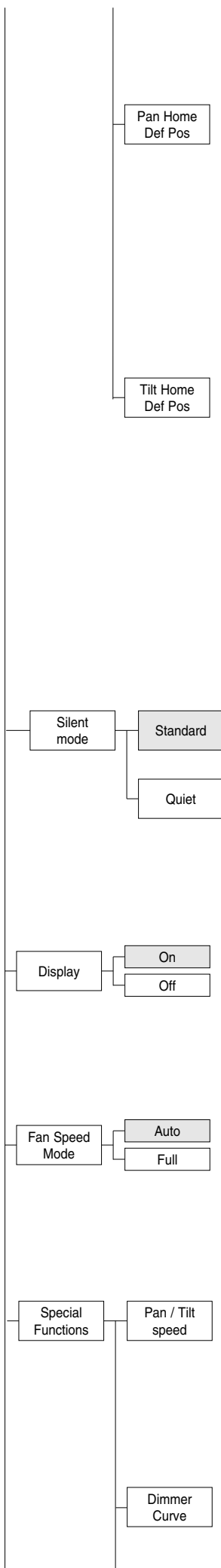

Standard: Pan & Tilt are simultaneously reset.

Sequenced: Tilt is reset first followed by Pan.

3) Press **OK** to confirm the selection or LEFT to keep the current setting.

Pan Home Def Pos

Lets you assign the Pan channel “home” position at the end of Reset, without a DMX input signal.

1) Press **OK**, the current setting appears on the display.

2) Use the UP and DOWN keys to select one of the following settings:

0 degree

90 degrees

180 degrees

270 degrees (default)

3) Press **OK** to confirm the selection or LEFT to keep the current setting.

Tilt Home Def Pos

Lets you assign the Tilt channel “home” position at the end of Reset, without a DMX input signal.

1) Press **OK**, the current setting appears on the display.

2) Use the UP and DOWN keys to select one of the following settings:

0%

12.5%

25%

50% (default)

75%

87.5%

100%

3) Press **OK** to confirm the selection or LEFT to keep the current setting.

SILENT MODE

It lets you select the “Silent Mode” from the two available.

1) Press **OK** the current setting appears on the display.

2) Use the UP and DOWN keys to select one of the following settings:

Standard: Maximum speed and consequently maximum effects/fans noise level.

Quiet: Regulates the speed of the effects (Pan, Tilt, Zoom, Zoom rotation) and of the fans thereby reducing their noise level.

3) Press **OK** to confirm the selection or LEFT to keep the current setting.

DISPLAY

Used for automatically reduce brightness on the display after about 30 seconds in idle.

1) Press **OK** - the current settings appear on the display (On or Off).

2) Use the UP and DOWN keys to enable (On) or disable (Off) the decreasing of display brightness.

3) Press **OK** to confirm the selection or LEFT to keep current settings.

FAN SPEED MODE

Allows you to set how to manage the fan speed of the head of the fixture, select between the two available:

- **Auto:** the head’s fan varies the speed depending on the temperature detected on the LED.

- **Full:** the head’s fan is always at full speed.

SPECIAL FUNCTIONS

Pan / Tilt speed

Lets you select two different Pan and Tilt speeds.

1) Press **OK** - the current setting appears on the display.

2) Use the UP and DOWN keys to select one of the following settings:

- **Normal**

- **Fast**

3) Press **OK** to confirm the selection or LEFT to keep current settings.

Dimmer Curve

Lets you select four different Dimmer channel curves.

1) Press **OK** - the current setting appears on the display.

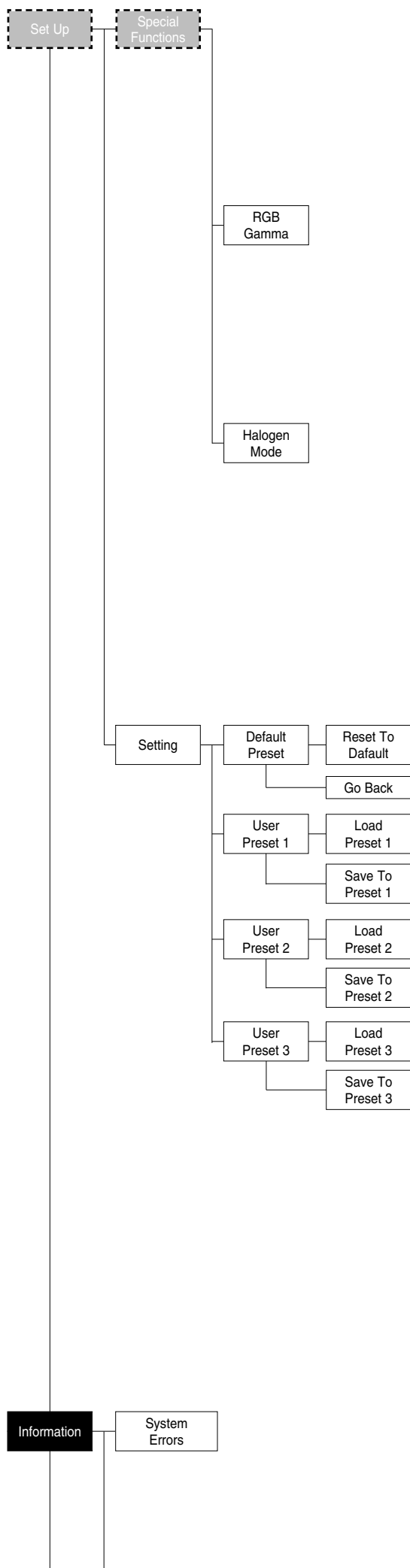

- 2) Use the UP and DOWN keys to select one of the following settings:
 - Curve 1
 - Curve 2
 - Curve 3
 - Curve 4
- 3) Press to confirm the selection or LEFT to keep current settings.

RGB Gamma

Lets you select three different RGBW gamma curves.

- 1) Press - the current setting appears on the display.
- 2) Use the UP and DOWN keys to select one of the following settings:
 - Gamma 1.0
 - Gamma 1.5
 - Gamma 2.0
- 3) Press to confirm the selection or LEFT to keep current settings.

Halogen Mode

Lets you select five different halogen lamp simulations.

- 1) Press - the current setting appears on the display.
- 2) Use the UP and DOWN keys to select one of the following settings:
 - Halogen OFF
 - Halogen Lamp 1 - 750 W
 - Halogen Lamp 2 - 1000 W
 - Halogen Lamp 3 - 1200 W
 - Halogen Lamp 4 - 2000 W
 - Halogen Lamp 5 - 2500 W
- 3) Press to confirm the selection or LEFT to keep current settings.

SETTING

Used to save 3 different settings of the items in the options menu and relative submenus.

- 1) Press - "Default preset" appears on the display.
- 2) Use the UP and DOWN keys to select one of the following configurations:
 - Default preset (*)
 - User preset 1
 - User preset 2
 - User Preset 3
- 3) Press - "Load preset X" appears on the display.
- 4) Use the UP and DOWN keys to select:
 - Load preset X to recall a previously stored configuration.
 - Save to preset X to store the current configuration.
 a confirmation message (Are you sure?) appears on the display.
- 5) Select YES to confirm the selection or NO to keep the current setting and return to the next higher level.

(*) DEFAULT PRESET

By pressing the RIGHT key and the LEFT key simultaneously once entered in the "main menu" it is possible to quickly (short cut) reset the default settings (DEFAULT PRESET).

Used for restoring default values on all options menu items and relevant submenus.

- 1) Press , a confirmation message (Are you sure?) appears on the display.
- 2) Select YES to confirm the selection or NO to keep current setting.

INFORMATION MENU

SYSTEM ERRORS

Shows a list of warnings and messages relevant to errors occurred since the fixtures switching-on.

- 1) Pressing you are allowed to reset the SYSTEM ERRORS list.
 - A confirmation message (Are you sure you want to clear error list ?) appears on the display.
- 2) Select YES to reset the list or NO to go back.

Fixture Hours	Total	XXX
	Partial	XXX
Reset...		

LED Energy Tot

System Version	Board	Revis.	Hw.rv.
	CPU brd	x.x.x	x.x
	com.dev	x.x	
	0: PT-3f	x.x	x.x
1: Ld - Kxx	x.x	x.x	

Board Diagnost.	Board	Status	Err%
	0: PT-3f	Good	0.00
	1: Ld - Kxx	Good	0.00

Dmx Monitor

Fans Monitor	Fan	Speed (RPM)
	PwrSp	XXXX
	Head	XXXX

Sensor Status

Network params

FIXTURE HOURS

Used for displaying projector operating hours (total and partial).

1) Press **OK** - Hours total and partial appears on the display.

Total counter

Counts the number of projector working life hours (from manufacture to date).

Partial counter

Counts the number of partial projector working life hours since the last reset to date.

2) Press **OK** to reset partial projector working hours a confirmation message (Are you sure?) appears on the display.

3) Select YES to reset partial projectors counter or NO to keep the current setting and return to the top menu level.

LED ENERGY TOT

Lets you view total LED working hours.

1) Press **OK** - to display total and partial Watts/hour:

Total

Total LED working hours from construction to date.

Partial

LED working hours from last reset to date.

2) Press **OK** to reset the partial counter. A confirmation appears on the screen (Are you sure?)

3) Select YES to reset the partial counter or NO to keep the current setting and open the next menu level.

SYSTEM VERSION

Used for displaying the software and hardware version of each board installed in the projector.

CPU brd (CPU board)

0: PT-3f (Scheda Pan / Tilt)

1: Ld - Kxx (Scheda LED)

BOARD DIAGNOSTIC

Used for displaying the status error of each board installed in the projector:

0: PT-3f (Scheda Pan / Tilt)

1: Ld - Kxx (Scheda LED)

DMX MONITOR

Used for displaying the projector DMX channel level in bit (Val) and in percentage (Perc).

FANS MONITOR

Used for displaying the speed of each fan installed in the projector:

PwrSp (fan PSU)

Head (fan head)

SENSOR STATUS

It lets you check the correct operations of each "sensor" installed in the projector, each channel is associated with one of the following three parameters:

- n.a.= sensor not available
- ON= sensor working
- OFF= sensor defective

NETWORK PARAMS

Allows the "Network" parameters of the projector to be displayed or:

IP address: Internet Protocol address (two projectors must not have the same IP address)

IP mask: 255.0.0.0

Mac address: Media Access Control: the projector's Ethernet Address.

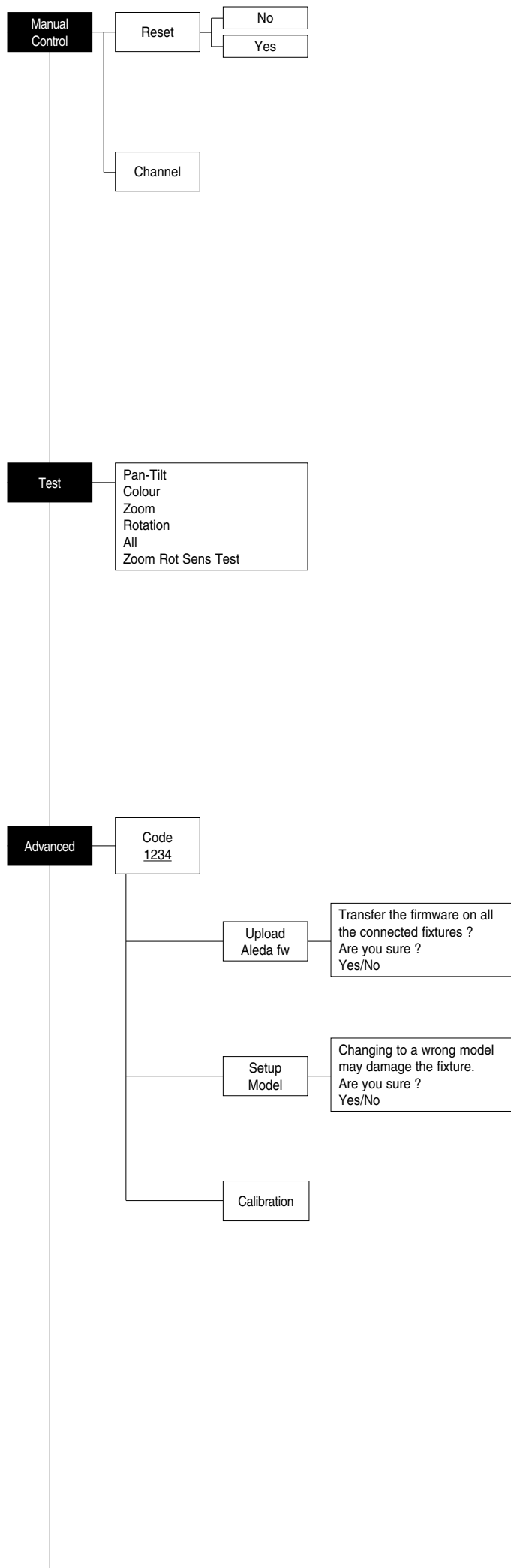

MANUAL CONTROL

RESET

Used for resetting the projector.

- 1) Press **OK** to reset the projectors, a confirmation message (Are you sure ?) appears on the display.
- 2) Select YES to starting reset the fixture or NO to keep the current setting and return to the top menu level.

CHANNEL

Used for setting channel levels from the projector control panel.

- 1) Press **OK** - the first channel appears on the display.
- 2) Use the UP **▲** and DOWN **▼** keys to select the required channel:
- 3) Press **OK** and use the UP **▲** and DOWN **▼** keys to select the required DMX level (value between 0 and 255).
- 4) Press LEFT **◀** to return to the top menu level.

TEST MENU

TEST

Allows you to check the proper functioning of effects.

- 1) Press **OK** to return to the top menu level.
- 2) Use the UP **▲** and DOWN **▼** keys to select the required test.
- 3) Press **OK** to confirm the selection or LEFT **◀** to keep current settings.

Test sequence:

Pan - Tilt effects (Pan & Tilt)

Colours

Zoom

Zoom rotation

All effects

Zoom Rotation Sensor Test

ADVANCED MENU

To enable the "Advanced Menu" set up the "Access code" (1234) using the UP **▲**, DOWN **▼**, RIGHT **▶** keys.

Press **OK** - "Menu advanced" appears on the display

UP LOAD FIRMWARE

Allows you to transfer the firmware from 1 fixture to all the connected fixtures.

- 1) Press **OK** , a confirmation message appears on the display.
- 2) Select YES to start the firmware loading or NO to keep the current setting and return to the top menu level

SETUP MODEL

Allows you to change the default model of projector.

- 1) Press **OK** a confirmation message appears on the display.
- 2) Select YES to define the model of projector or NO to keep the current setting and return to the top menu level.

CALIBRATION

Allows you to adjust effects from the control panel to obtain perfect uniformity between the projectors.

- 1) Press **OK** - "channels" appears on the display.
- 2) Using the UP **▲** and DOWN **▼** keys, select the effect you wish to regulate.
- 3) Press **OK** and use the RIGHT **▶**, UP **▲** and DOWN **▼** buttons to make the adjustment by setting a value between 0 and 255.
- 4) Press **OK** to confirm the selection or LEFT **◀** to keep current settings and return to the top level.

FACTORY DEFAULT

Allows you to restore default values of all channels (128).

- 1) Press **OK** – a confirmation message appears on the display (Reset calibration to factory default ?).
- 2) Select YES to reset calibration to factory default or NO to keep the current setting and return to the top menu level.

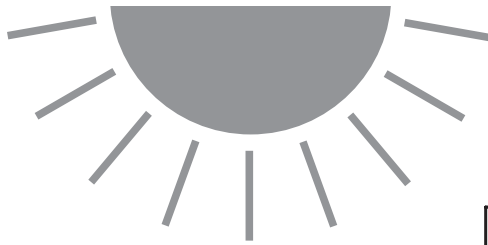

WARNING:
no alcohol



Light collimation system

This product contains internal light collimation system. Avoid intense light from any angle.

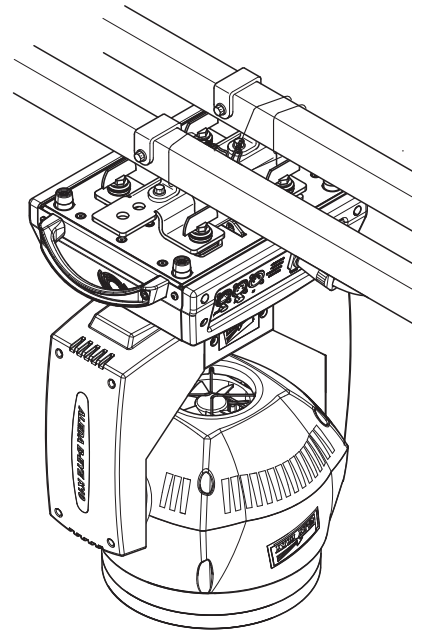
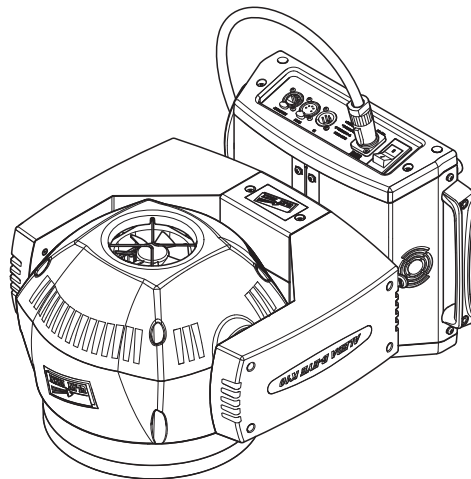
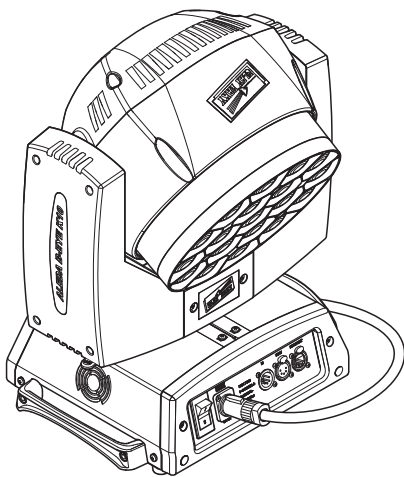
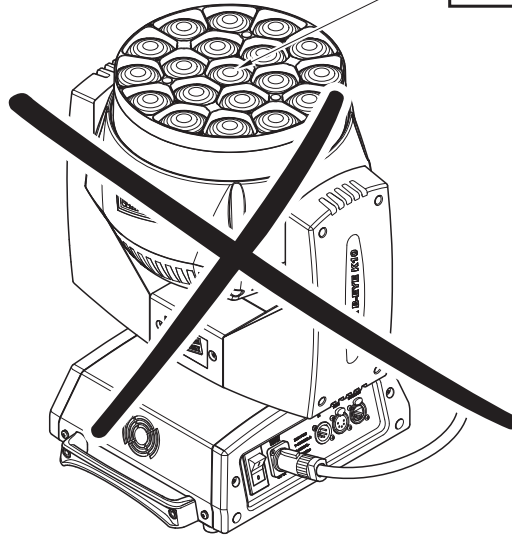

CAUTION:

• **Light collimation system**

This product contains internal light collimation system. Avoid intense light from any angle.

To avoid damage to the internal parts of the fixture when the fixture is not working, is recommended to turn the head down before turning the fixture off, so that the front lenses of the fixture are invested as little as possible from the sun or any intense light.

- Set channel 20 (Zoom) to 255-bit before turning off the projector to facilitate the packaging of the projector.

- To ensure optimal operation and performance for a long time it is essential to periodically clean the parts subject to dust and grease deposits. The frequency with which the following operations are to be carried out depends on various factors, such as the amount of the effects and the quality of the working environment (air humidity, presence of dust, salinity, etc.).

It is recommended that the projector undergoes an annual service by a qualified technician for special maintenance involving at least the following operations:

- General cleaning of internal parts.
- Restoring lubrication of all parts subject to friction, using lubricants specifically supplied by Clay Paky.
- General visual check of the internal components, cabling, mechanical parts, etc.
- Electrical, photometric and functional checks; eventual repairs.

Cleaning the lenses

Only use neutral soap and water to clean the lenses, then dry it carefully with a soft, non-abrasive cloth. (WARNING: the use of alcohol or any other detergent could damage the lenses).

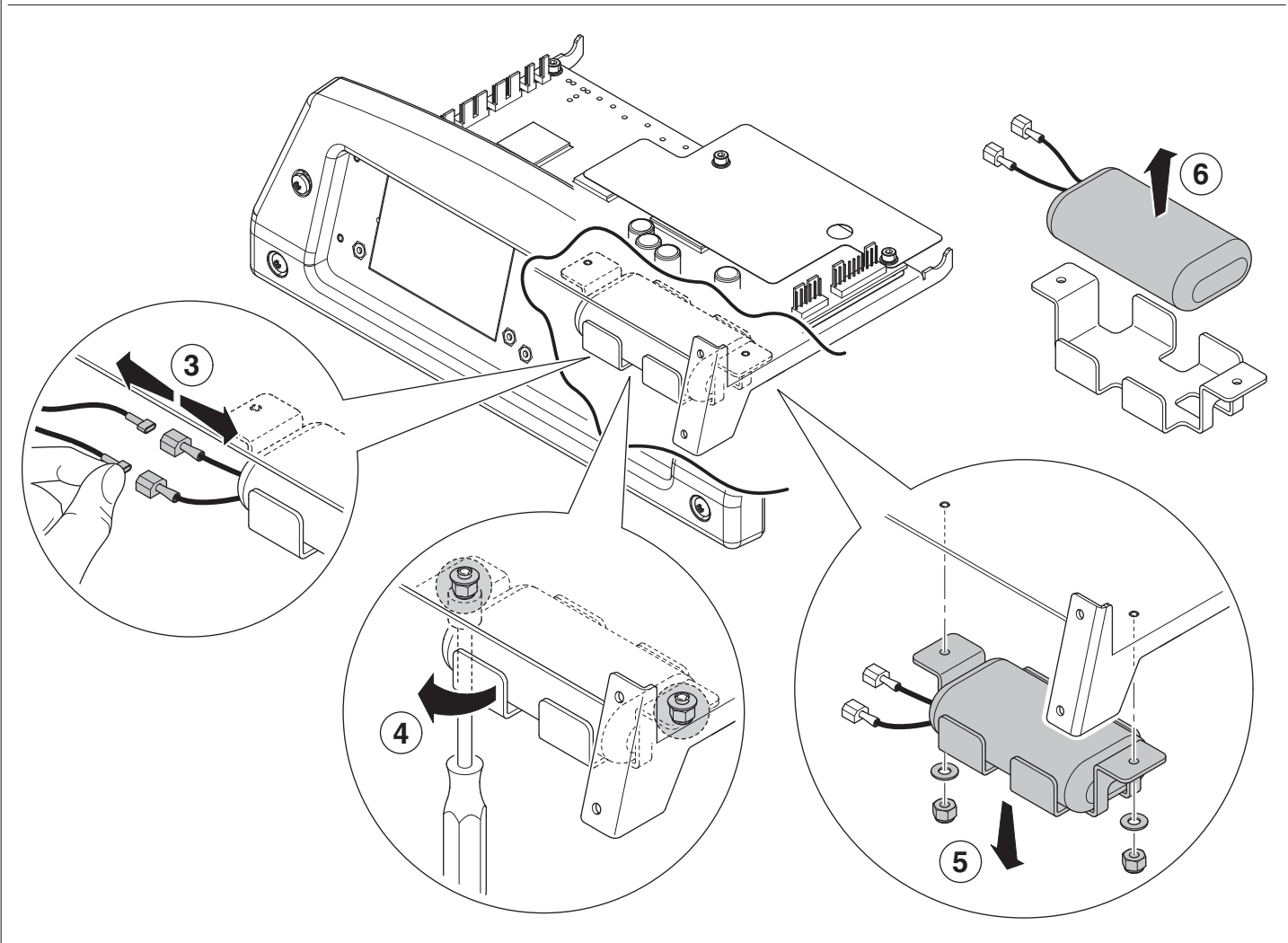
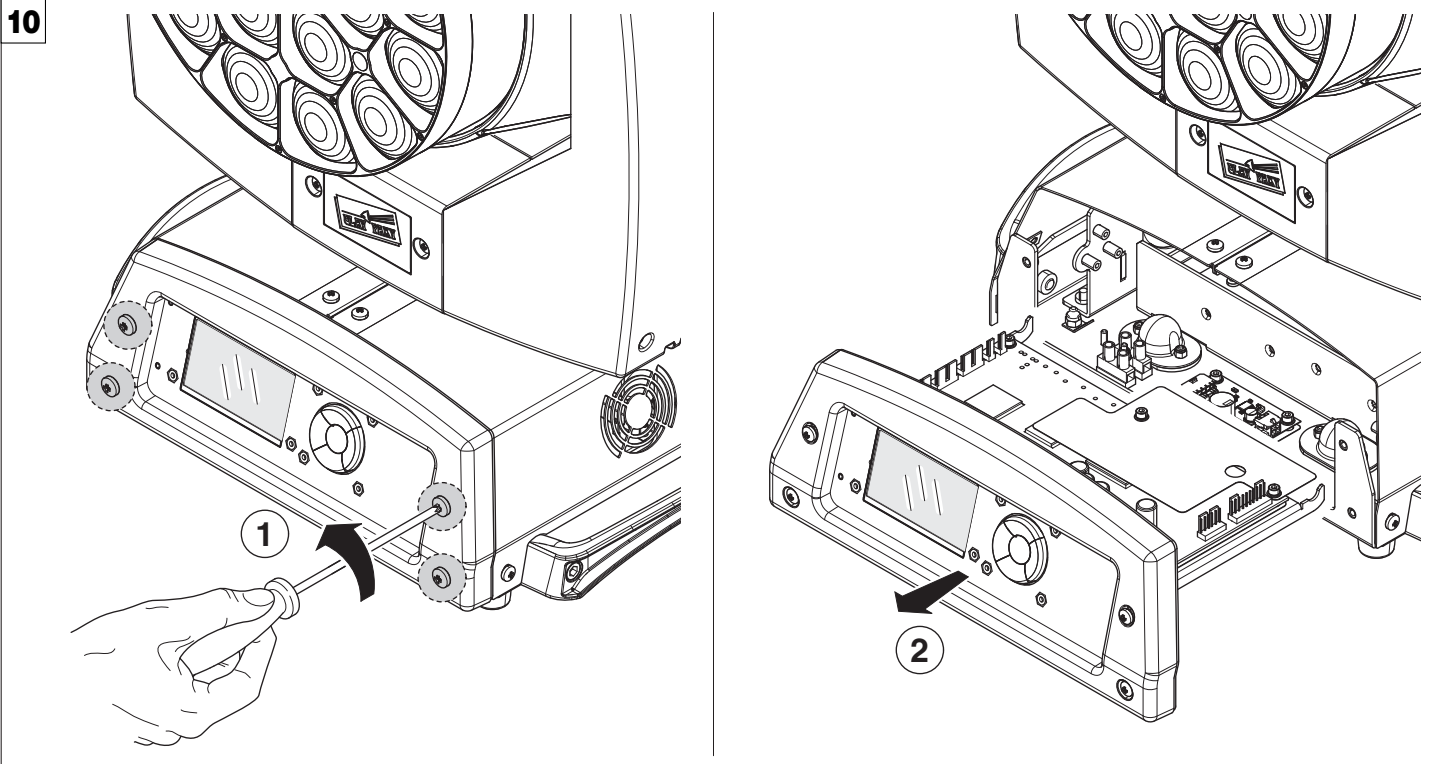

Battery removal - Fig. 10



This product contains a rechargeable lead-acid or lithium iron tetraphosphate battery. To preserve the environment, please dispose the battery at the end of its life according to the regulation in force.

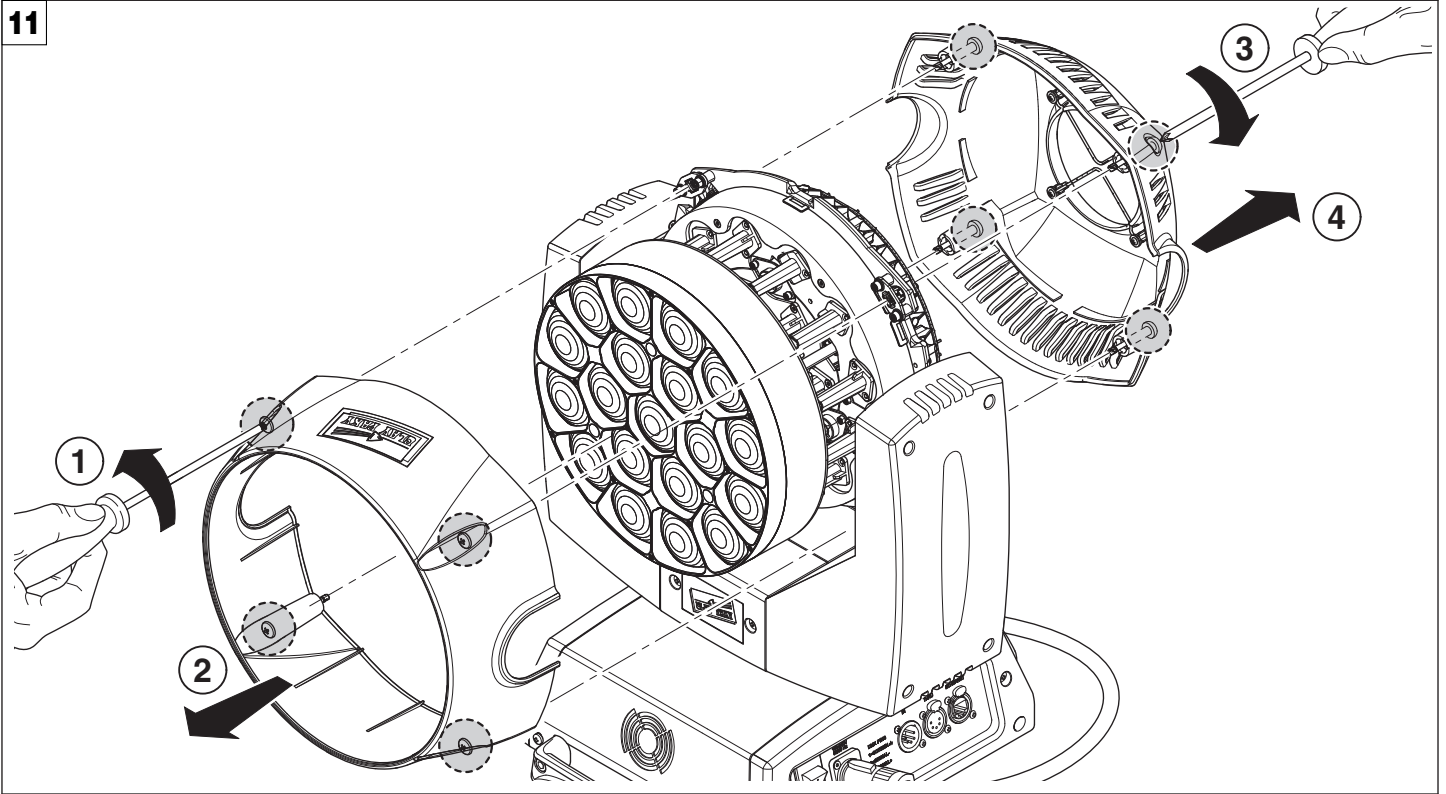

Opening the covers - Fig. 11

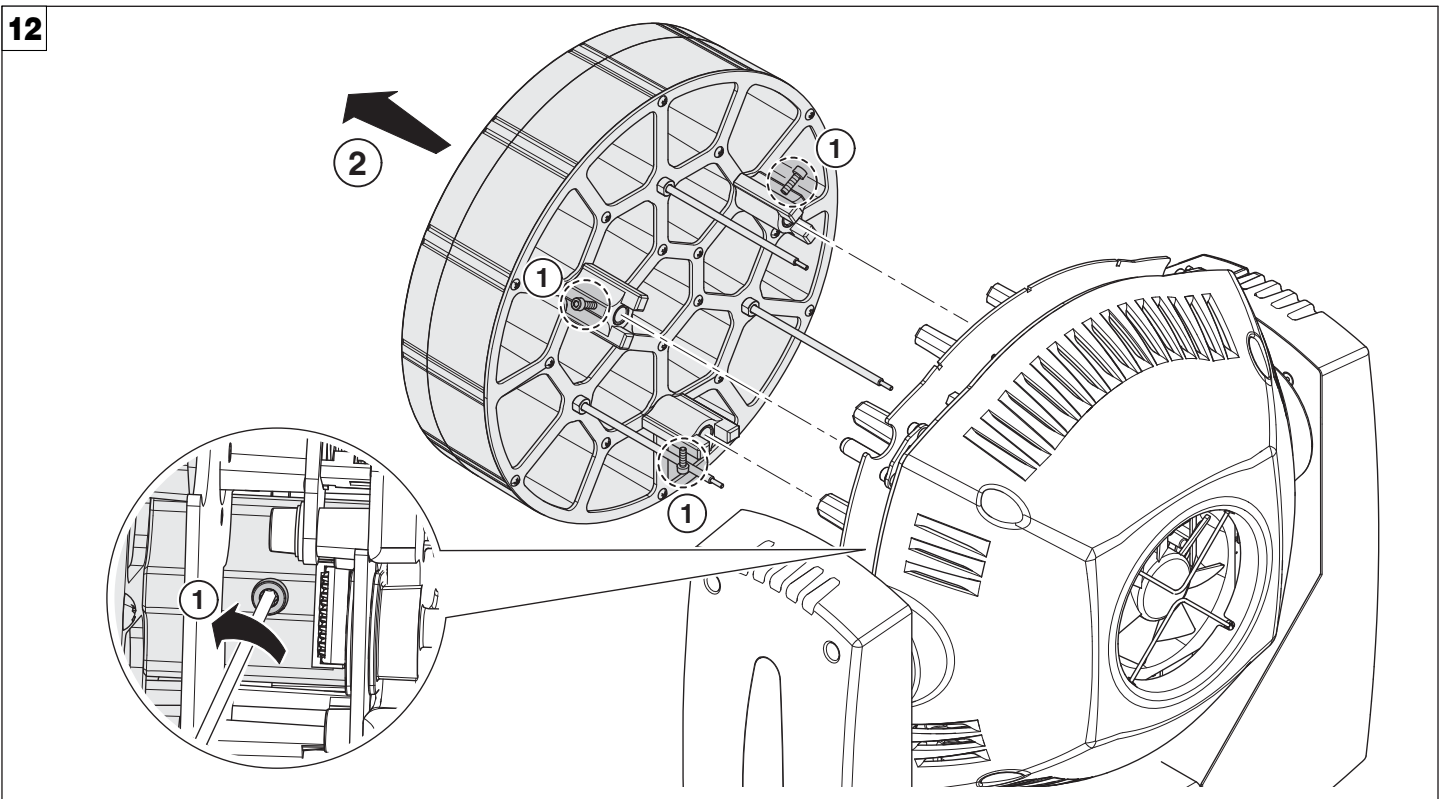

Removing/Assembling the lens unit - Fig. 12

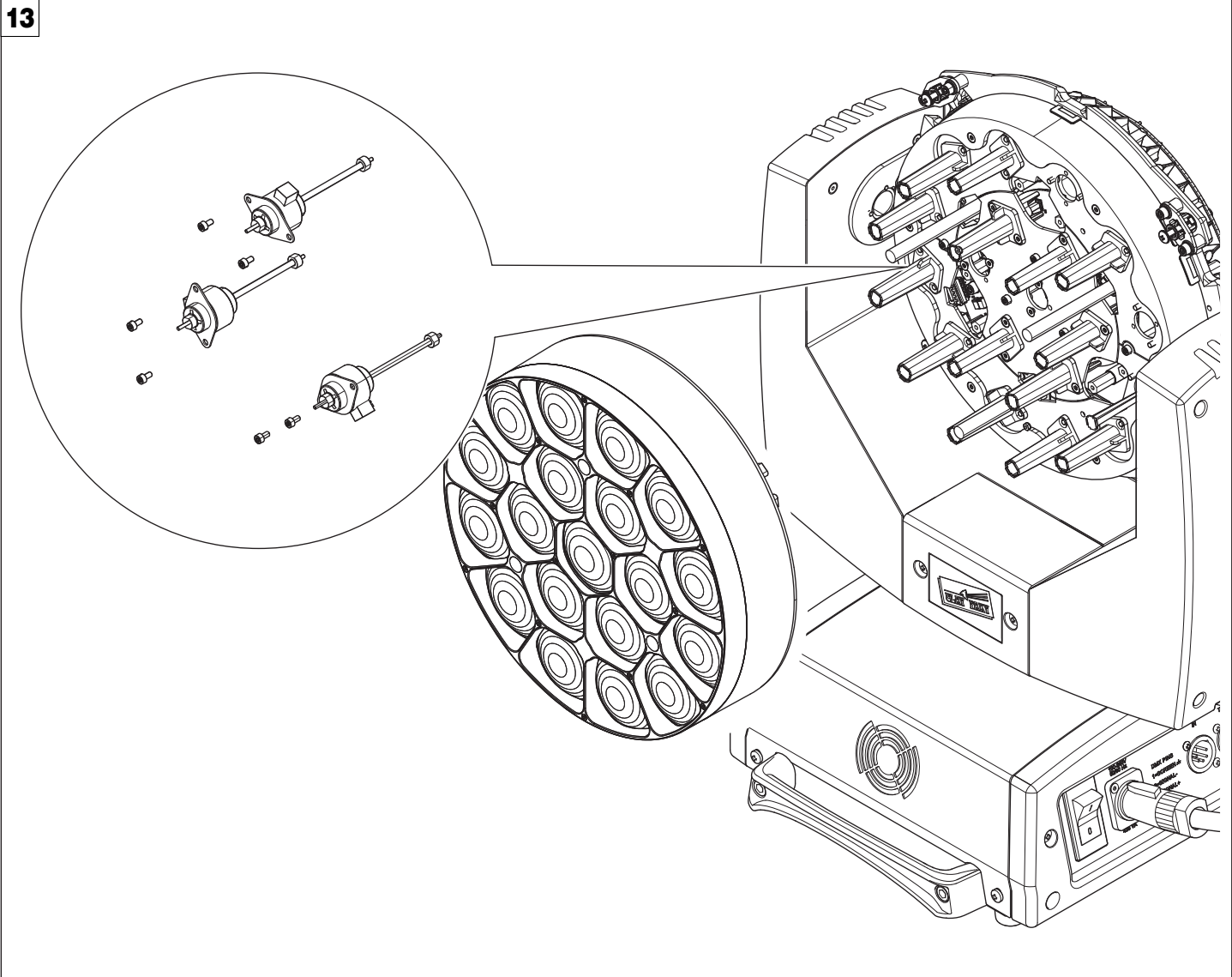

Replacing the line actuator - Fig. 13

CAUSE AND SOLUTION OF PROBLEMS

THE PROJECTOR WILL NOT SWITCH ON			PROBLEMS
ELECTRONICS NON-OPERATIONAL			
DEFECTIVE PROJECTION			
REDUCED LUMINOSITY			
	POSSIBLE CAUSES	CHECKS AND REMEDIES	
●	No mains supply.	Check the power supply voltage.	
●	● LED exhausted or defective.	Call an authorised technician.	
	● Signal transmission cable faulty or disconnected.	Replace the cables.	
	● Incorrect addressing.	Check addresses (see instructions).	
	● Fault in the electronic circuits.	Call an authorised technician.	
	● Lenses or reflector broken	Call an authorised technician.	
	● ● Dust or grease deposited.	Clean (see instructions).	

TECHNICAL INFORMATION

A.Leda B-EYE K10

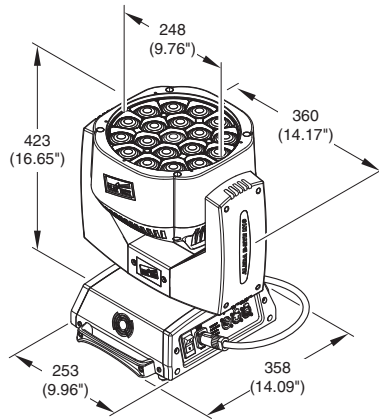
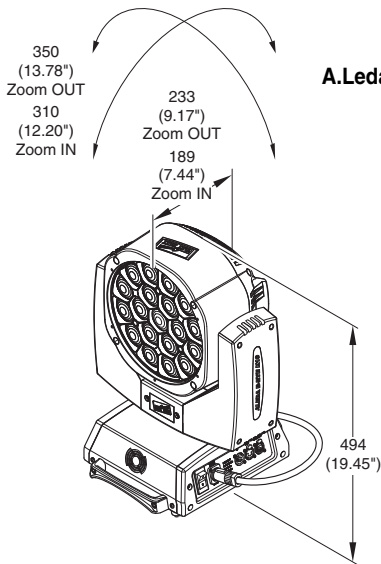

A.Leda B-EYE K10 easy

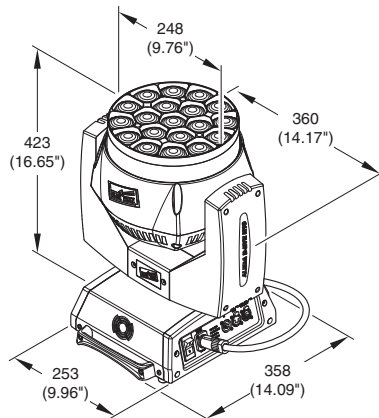
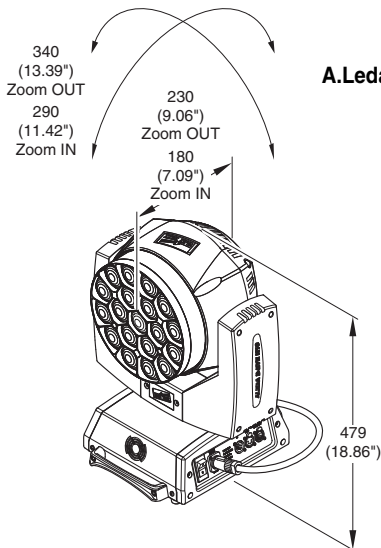

A.Leda B-EYE K20

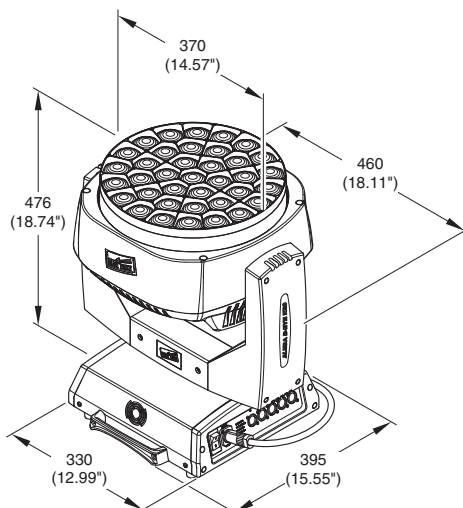
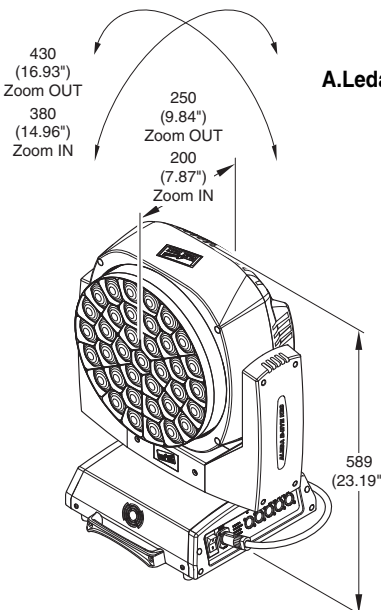

Power supplies available
100-240V 50/60Hz

Input power
• K20 - 750VA
• K10 - 450VA

Total output
B-EYE K10: 5500 lumens
B-EYE K10 Easy: 4800 lumens
B-EYE K20: 9800 lumens

LED source
Osram Ostar RGBW LED - 15W
Average LED life: 50.000 h

Motors
5 (k10), 7 (k20) stepper motors, operating with microsteps, totally microprocessor controlled.

Cooling
• High efficiency die-cast aluminium
• Forced ventilation

Inputs
• DMX 512
• Ethernet

Working position
Working in any position.

Moving Head
• Movement by means of two stepper motors, controlled by microprocessor.
• Automatic repositioning of PAN and TILT after accidental movement not controlled by control unit.
• Angle:
- PAN = 540°
- TILT = 210°

IP20 protection rating
• Protected against the entry of solid bodies larger than 12mm (0.47").
• No protection against the entry of liquids.

CE Marking
Complies with the following European Directives
- 2006/95/EC (LVD)
- 2004/108/EC (EMC)
- 2011/65/EU (RoHS).

Weights
• K10: 14.5 kg (31.14 lbs)
• K20: 21 kg (46.3 lbs)

CHANNEL FUNCTION

A.LEDA B-EYE K10 EASY

BASIC ENGINE

STANDARD

CHAN- NEL	CHANNEL MODE
1	Red
2	Red fine
3	Green
4	Green fine
5	Blue
6	Blue fine
7	White
8	White fine
9	Linear CTO
10	Macro colour
11	Strobe
12	Dimmer
13	Dimmer Fine
14	Pan
15	Pan Fine
16	Tilt
17	Tilt Fine
18	Function
19	Reset
20	Zoom

SHAPES

CHAN- NEL	CHANNEL MODE
1	Red
2	Red fine
3	Green
4	Green fine
5	Blue
6	Blue fine
7	White
8	White fine
9	Linear CTO
10	Macro colour
11	Strobe
12	Dimmer
13	Dimmer Fine
14	Pan
15	Pan Fine
16	Tilt
17	Tilt Fine
18	Function
19	Reset
20	Zoom
21	Shape Selection
22	Shape Speed
23	Shape Fade
24	Shape R
25	Shape G
26	Shape B
27	Shape W
28	Shape Dimmer
29	Background Dimmer
30	Shape Transition
31	Shape Offset
32	Foreground Strobe
33	Background Strobe
34	Background Select

PIXEL ENGINE

Pixel Engine need to be enabled through the FUNCTION channel (bit 103-105).

RGB

CHAN- NEL	CHANNEL MODE
1	Red LED 1
2	Green LED 1
3	Blue LED 1
...	Red LED ...
...	Green LED ...
...	Blue LED ...
55	Red LED 19
56	Green LED 19
57	Blue LED 19

RGBW

CHAN- NEL	CHANNEL MODE
1	Red LED 1
2	Green LED 1
3	Blue LED 1
4	White LED 1
...	Red LED ...
...	Green LED ...
...	Blue LED ...
...	White LED ...
73	Red LED 19
74	Green LED 19
75	Blue LED 19
76	White LED 19

A.LEDA B-EYE K10

BASIC ENGINE

STANDARD

CHAN- NEL	CHANNEL MODE
1	Red
2	Red fine
3	Green
4	Green fine
5	Blue
6	Blue fine
7	White
8	White fine
9	Linear CTO
10	Macro colour
11	Strobe
12	Dimmer
13	Dimmer Fine
14	Pan
15	Pan Fine
16	Tilt
17	Tilt Fine
18	Function
19	Reset
20	Zoom
21	Zoom Rotation

SHAPES

CHAN- NEL	CHANNEL MODE
1	Red
2	Red fine
3	Green
4	Green fine
5	Blue
6	Blue fine
7	White
8	White fine
9	Linear CTO
10	Macro colour
11	Strobe
12	Dimmer
13	Dimmer Fine
14	Pan
15	Pan Fine
16	Tilt
17	Tilt Fine
18	Function
19	Reset
20	Zoom
21	Zoom Rotation
22	Shape Selection
23	Shape Speed
24	Shape Fade
25	Shape R
26	Shape G
27	Shape B
28	Shape W
29	Shape Dimmer
30	Background Dimmer
31	Shape Transition
32	Shape Offset
33	Foreground Strobe
34	Background Strobe
35	Background Select

PIXEL ENGINE

Pixel Engine need to be enabled through the FUNCTION channel (bit 103-105).

RGB

CHAN- NEL	CHANNEL MODE
1	Red LED 1
2	Green LED 1
3	Blue LED 1
...	Red LED ...
...	Green LED ...
...	Blue LED ...
55	Red LED 19
56	Green LED 19
57	Blue LED 19

RGBW

CHAN- NEL	CHANNEL MODE
1	Red LED 1
2	Green LED 1
3	Blue LED 1
4	White LED 1
...	Red LED ...
...	Green LED ...
...	Blue LED ...
...	White LED ...
73	Red LED 19
74	Green LED 19
75	Blue LED 19
76	White LED 19

A.LEDA B-EYE K20

BASIC ENGINE

STANDARD

CHAN- NEL	CHANNEL MODE
1	Red
2	Red fine
3	Green
4	Green fine
5	Blue
6	Blue fine
7	White
8	White fine
9	Linear CTO
10	Macro colour
11	Strobe
12	Dimmer
13	Dimmer Fine
14	Pan
15	Pan Fine
16	Tilt
17	Tilt Fine
18	Function
19	Reset
20	Zoom
21	Zoom Rotation

SHAPES

CHAN- NEL	CHANNEL MODE
1	Red
2	Red fine
3	Green
4	Green fine
5	Blue
6	Blue fine
7	White
8	White fine
9	Linear CTO
10	Macro colour
11	Strobe
12	Dimmer
13	Dimmer Fine
14	Pan
15	Pan Fine
16	Tilt
17	Tilt Fine
18	Function
19	Reset
20	Zoom
21	Zoom Rotation
22	Shape Selection
23	Shape Speed
24	Shape Fade
25	Shape R
26	Shape G
27	Shape B
28	Shape W
29	Shape Dimmer
30	Background Dimmer
31	Shape Transition
32	Shape Offset
33	Foreground Strobe
34	Background Strobe
35	Background Select

PIXEL ENGINE

Pixel Engine need to be enabled through the FUNCTION channel (bit 103-105).

RGB

CHAN- NEL	CHANNEL MODE
1	Red LED 1
2	Green LED 1
3	Blue LED 1
...	Red LED ...
...	Green LED ...
...	Blue LED ...
109	Red LED 37
110	Green LED 37
111	Blue LED 37

RGBW

CHAN- NEL	CHANNEL MODE
1	Red LED 1
2	Green LED 1
3	Blue LED 1
4	White LED 1
...	Red LED ...
...	Green LED ...
...	Blue LED ...
...	White LED ...
145	Red LED 37
146	Green LED 37
147	Blue LED 37
148	White LED 37

NOTE: On conclusion of resetting in case of absence of DMX signal, Pan & Tilt move to the "Home" position (Pan 128 bit - Tilt 128 bit) all the others channels stay at 0 bit.

- RED
- GREEN
- BLUE
- WHITE



BIT	EFFECT
255	LED ON
0	LED OFF

- RED FINE
- GREEN FINE
- BLUE FINE
- WHITE FINE



BIT	EFFECT
255	UP
0	LOW

- LINEAR CTO

BIT	EFFECT
255	2500 K
...	...
224	3200 K
...	...
188	4000 K
...	...
144	5000 K
...	...
117	5600 K
...	...
99	6000 K
...	...
54	7000 K
...	...
10	8000 K
0-9	UNUSED RANGE

Note: If CTO channel is active, the WHITE channel is disabled.

- MACRO COLOUR

BIT	LEE REFERENCE	COLOUR	BIT VALUE			
			R	G	B	W
209-255	-	White	255	235	66	255
208	-	Dirty White	255	255	122	255
207	197	Alice Blue	128	255	143	0
191-206	181	Congo Blue	77	0	255	0
184-190	174	Dark Steel Blue	181	255	95	0
180-183	170	Deep lavender	255	168	64	0
179	169	Lilac Tint	255	199	49	0
175-178	165	Daylight Blue	82	214	90	0
174	164	Flame Red	255	46	2	0
172-173	162	Bastard Amber	255	181	28	0
168-171	158	Deep Orange	222	84	0	0
162-167	152	Pale Gold	253	171	26	0
157-161	147	Apricot	255	143	13	0
151-156	141	Bright Blue	0	255	87	0
149-150	139	Primary Green	77	255	0	0
147-148	137	Special lavender	219	197	79	0
146	136	Pale Lavender	255	197	61	0
145	135	Deep Golden Amber	255	58	0	0
142-144	132	Medium Blue	0	255	143	0
138-141	128	Bright Pink	255	53	36	0
136-137	126	Mauve	227	41	56	0
134-135	124	Dark Green	84	255	13	0
131-133	121	Leaf Green	206	255	0	0
129-130	119	Dark Blue	0	186	255	0
128	118	Light Blue	74	255	82	0
127	117	Steel Blue	206	255	56	0
126	116	Med Blu Green	206	255	56	0
125	115	Peacock Blue	51	255	51	0
123-124	113	Magenta	255	20	15	0
121-122	111	Dark Pink	255	109	33	0
120	110	Middle Rose	217	130	28	0
119	109	Light Salmon	255	138	31	0
118	108	English Rose	255	148	23	0
117	107	Light Rose	255	141	31	0
115-116	105	Orange	255	122	0	0
114	104	Deep Amber	255	166	0	0
113	103	Straw	230	160	0	69
112	102	Light Amber	237	163	0	0
110-111	100	Spring Yellow	245	202	0	0
100-109	90	Dark yellow green	41	219	0	0
89-99	79	Just Blue	0	194	130	0
78-88	68	Sky Blue	0	255	135	0
68-77	58	Lavender	243	117	133	199
62-67	52	Light Lavender	243	117	39	197
49-61	39	Pink Carnation	255	107	0	130
46-48	36	Medium Pink	255	87	0	107
45	35	Light Pink	255	112	0	141
35-44	25	Sunrise Red	255	83	2	0
32-34	22	Dark Amber	255	65	0	0
31	21	Gold Amber	255	100	0	0
30	20	Medium Amber	255	135	0	0
29	19	Fire	255	56	0	0
27-28	17	Surprise Peach	198	114	9	0
23-26	13	Straw Tint	152	115	9	0
20-22	10	Medium Yellow	156	126	0	0
19	-	Black	0	0	0	0
18	-	White 5000 K	255	137	0	193
17	-	White 3700 K	255	201	25	255
16	-	White 7000 K	216	237	61	255
15	-	Magenta	255	0	255	0
14	-	Yellow	255	255	0	0
13	-	Cyan	0	255	255	0
12	-	Blue	0	0	255	0
11	-	Green	0	255	0	0
10	-	Red	255	0	0	0
0-9	-	Macro color OFF	-	-	-	-

• STOP STROBE - FOREGROUND STROBE - BACKGROUND STROBE



BIT	EFFECT
252 - 255	OPEN
239 - 251	RANDOM FAST STROBE
226 - 238	RANDOM MEDIUM STROBE
213 - 225	RANDOM SLOW STROBE
208 - 212	OPEN
207	FAST PULSATION (25 flash/sec)
108	SLOW PULSATION (0,5 flash/sec)
104 - 107	OPEN
103	FAST STROBE (25 flash/sec)
4	SLOW STROBE (1 flash/sec)
0 - 3	CLOSED

• DIMMER



BIT	EFFECT
255	FULL LIGHT
0	NO LIGHT

• DIMMER FINE



BIT	EFFECT
255	UP
0	LOW

• PAN

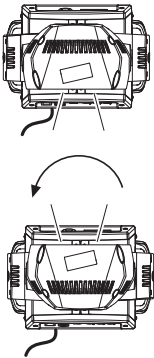

BIT
255
0

• PAN FINE

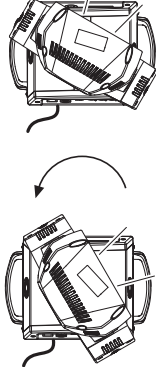

BIT
255
0

Operation with option InvertPan ⇄ Off

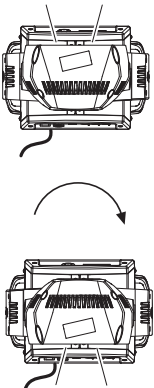

BIT
255
0

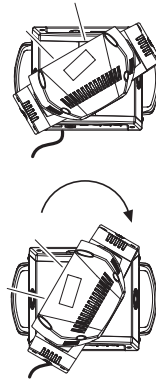

BIT
255
0

Operation with option InvertPan ⇄ On

• TILT

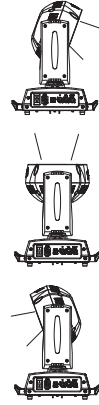

BIT
255
0

Operation with option InvertTilt ⇄ Off

• TILT FINE

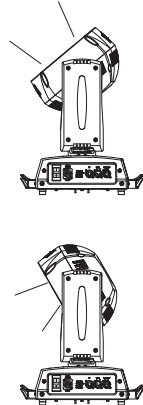

BIT
255
0

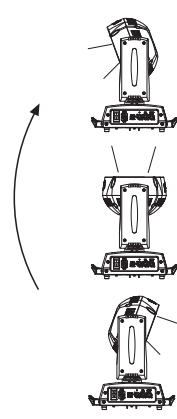

BIT
255
0

Operation with option InvertTilt ⇄ On

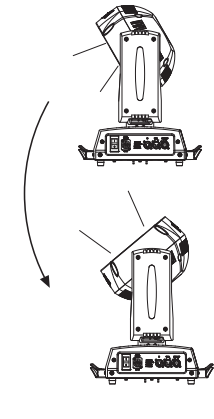

BIT
255
0

• FUNCTION

BIT	EFFECT
106 - 255	Reserved
103 - 105	Pixel map enabled
98 - 102	Halogen Lamp Simulation Linear CTO @ 0 bit
93 - 97	Halogen Lamp Simulation Linear CTO @ 0 bit
88 - 92	Halogen Lamp Simulation Linear CTO @ 0 bit
83 - 87	Halogen Lamp Simulation Linear CTO @ 0 bit
78 - 82	Halogen Lamp Simulation Linear CTO @ 0 bit
73 - 77	Halogen Lamp Simulation OFF (Default)
68 - 72	RGBW Gamma curve 3 - gamma = 2.0
63 - 67	RGBW Gamma curve 2 - gamma = 1.5
58 - 62	RGBW Gamma curve 1 - gamma = 1.0
52 - 57	Dimmer Curve 4
48 - 52	Dimmer Curve 3
43 - 47	Dimmer Curve 2
38 - 42	Dimmer Curve 1
24 - 37	Pan Tilt Normal
12 - 24	Pan Tilt Fast (Default)
0 - 11	Function off - rearmed

The functions are activated passing through the "unused range" and staying 5 seconds in necessary level apart for the range 103-105 (Pixel map enabled) that is immediate. Last selected function still active. Enable setting a new function.

DIMMER CURVE 1 - GAMMA 1 LINEAR

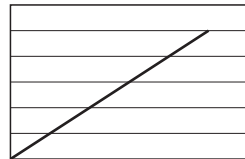

DIMMER CURVE 3 - GAMMA 2,0

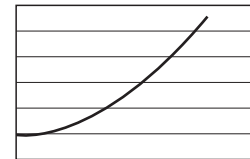

DIMMER CURVE 2 - GAMMA 1,5

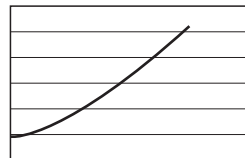

DIMMER CURVE 4 - S

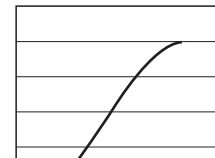

• RESET

BIT	EFFECT
255	COMPLETE RESET
.....	Complete reset is activated passing through the unused range and staying 5 seconds in complete reset levels
128	COMPLETE RESET
127	PAN / TILT RESET
.....	Pan / Tilt reset is activated passing through the unused range and staying 5 seconds in Pan / Tilt reset levels
77	PAN / TILT RESET
76	ZOOM RESET
.....	Effects reset is activated passing through the unused range and staying 5 seconds in Effects reset levels.
26	ZOOM RESET
25	
0	UNUSED RANGE

• ZOOM



BIT	EFFECT
255	WIDE BEAM
.....	
0	NARROW BEAM

• ZOOM ROTATION



BIT	EFFECT
255	FAST ROTATION
.....	
193	SLOW ROTATION
191 - 192	STOP
190	SLOW ROTATION
.....	
128	FAST ROTATION
127	
.....	
0	LINEAR ROTATION

• ZOOM ROTATION (available on zoom channel from 0 bit to 42 bit)

BIT	MACRO EFFECT
193-255	CCW Rotation, speed from 3 RPH to 10 RPM
191-192	Stop rotation
128-190	CW Rotation, speed from 10 RPM to 3 RPH
127	Indexed zone. Lens angle = 60.00
126	Indexed zone. Lens angle = 59.52
....	
3	Indexed zone. Lens angle = 1.42
2	Indexed zone. Lens angle = 0.94
1	Indexed zone. Lens angle = 0.47
0	Indexed zone. Lens angle = 0

• ZOOM ROTATION (available on zoom channel at 255 bit only)

BIT	MACRO EFFECT
128-255	Lens offset angle: 0.00 degree
127	Lens offset angle: +4.00 degree
126	Lens offset angle: +3.94 degree
125	Lens offset angle: +3.87 degree
....	
1	Lens offset angle: +0.06 degree
0	Lens offset angle: 0.00 degree

• RED LED 1 to...
GREEN LED 1 to...
BLUE LED 1 to...
WHITE LED 1 to...



BIT	EFFECT
255	LED ON
.....	
0	LED OFF

SHAPE SPEED - SHAPE OFFSET - SHAPE FADE - BACKGROUND SELECT

Shape Selection	Shape Slot	Macro Name	On K10	On K20	Description	Random colors *1	SHAPE SPEED	SHAPE OFFSET	SHAPE FADE	BACKGROUND SELECT (*3)(*4)
0-7		Macro OFF	Yes	Yes		N.a.	N.a.	N.a.	N.a.	N.a.
8	1	Pixel 1	Yes	Yes	Static effects. The ring or rings used by the macro are turned-on with the foreground colour.	N.a.	N.a.	N.a.	N.a.	For K10: 0-7 = wash 8-15 = Bkgnd rings selection 16-255 = wash For K20: 0-7 = wash 8-23 = Bkgnd rings selection 24-255 = wash
9	2	Ring 1	Yes	Yes						
10	3	Ring 2	Yes	Yes						
11	4	Ring 3	No	Yes						
12	5	Pixel 1+Ring 1	Yes	Yes						
13	6	Pixel 1+Ring 2	Yes	Yes						
14	7	Pixel 1+Ring 3	No	Yes						
15	8	Single ring (Ramp -/+)	Yes	Yes		Yes	0-63 = Radius size, static. 64-158 = max to min speed, Closing effect 159-160 = STOP 161-255 = min to max speed, Opening effect	0-9 → continuous 10-255 → random distribution of flash	0-15 = Snap effect 16-255 = Fade effect and gamma selection	For K10: 0-7 = wash 8-15 = Bkgnd rings selection 16-255 = wash For K20: 0-7 = wash 8-23 = Bkgnd rings selection 24-255 = wash
16	9	Filled rings (ramp -/+)	Yes	Yes	Yes					
17	10	Open/Close 1	Yes	Yes	Yes					
18	11	Open/Close 2	Yes	Yes	Yes					
19	12	Random pixels 1	Yes	Yes		Yes	0-63 = Radius size, static. 64-158 = max to min speed, Closing effect 159-160 = STOP 161-255 = min to max speed, Opening effect	0-255 → select random distribution from 2 up to 20 fixtures	0-15 = Snap effect 16-255 = Fade effect and gamma selection	For K10: 0-7 = wash 8-15 = Bkgnd rings selection 16-254 = wash For K20: 0-7 = wash 8-23 = Bkgnd rings selection 24-254 = wash All Fixtures: 255 = Mirror Effect
20	13	Random pixels 2	Yes	Yes		Yes	0-63 = STOP 64-158 = max to min speed, Instant-on + fadeout. 159-160 = STOP. 161-255 = min to max speed, FadeIn + FadeOut.	0-255 → select pixel density		
21	14	Rainbow 1 (Variable speed)	Yes	Yes		N.a.	0-63 = Angle 0-360°, static. 64-158 = max to min speed, c.w rotation 159-160 = STOP 161-255 = min to max speed, cw rotation	0-255 → angle offset from 0 to 360°	0-15 = Snap effect 16-255 = Fade effect and gamma selection	For K10: 0-7 = wash 8-15 = Bkgnd rings selection 16-255 = wash For K20: 0-7 = wash 8-23 = Bkgnd rings selection 24-255 = wash
22	15	Rainbow 2 (Fixed speed with variable color offset)	Yes	Yes		N.a.	0-63 = STOP 64-158 = c.w rotation 159-160 = STOP 161-255 = cw rotation The value 64-158 or 161-255 change the rainbow angle offset (the orange starting angle).	N.a.	0-15 = Snap effect 16-255 = Fade effect and gamma selection	For K10: 0-7 = wash 8-15 = Bkgnd rings selection 16-255 = wash For K20: 0-7 = wash 8-23 = Bkgnd rings selection 24-255 = wash
23	16	Fan	Yes	Yes		N.a.	0-63 = angle offset, 0-360° 64-158 = max to min speed, c.w rotation 159-160 = STOP 161-255 = min to max speed, cw rotation	0-255 → angle offset from 0 to 360°	0-15 = Snap effect 16-255 = Fade effect and gamma selection	For K10: 0-7 = wash 8-15 = Bkgnd rings selection 16-255 = wash For K20: 0-7 = wash 8-23 = Bkgnd rings selection 24-255 = wash For all fixtures: - Macro 25, 26 255 = Mirror Effect with bkgnd color - Macro 27, 28, 29 255 = Show Alternative Color
24	17	Bar 1	Yes	Yes						
25	18	Half moon	Yes	Yes						
26	19	Triangle	Yes	Yes						
27	20	Segment 1	Yes	Yes						
28	21	Arc 1	Yes	Yes						
29	22	Arc 2	Yes	Yes						

*1: Random colors activation with foreground R,G,B,W = 0

*2: Aleda K10: macro 65 = Random on ring 1+3; macro 66 = Random on ring 2+3

*3: See Aleda K10 Background Rings Selection table

*4: See Aleda K20 Background Rings Selection table

Shape Selection	Shape Slot	Macro Name	On K10	On K20	Description	Random colors *1	SHAPE SPEED	SHAPE OFFSET	SHAPE FADE	BACKGROUND SELECT (*3)(*4)	
30	23	Bar 2 (Variable size)	Yes	Yes		N.a.	0-63 = STOP, indexed speed 64-158 = max to min speed, c.cw rotation. 159-160 = STOP. 161-255 = min to max speed cc rotation.	0-255 → select shape width	Linear fade	For K10: 0-7 = wash 8-15 = Bkgnd rings selection 16-254 = wash 255 = Mirror effect with bkgnd color For K20: 0-7 = wash 8-23 = Bkgnd rings selection 24-254 = wash 255 = Mirror effect with bkgnd color Note: Mirror effect unavailable for macro 31. Macro 67, 68, 69: the mirror effect is available only for options 1, 3, 9	
31	24	Random explosion	Yes	Yes		Yes		0-255 → select random distribution	Linear fade and wake length		
32	25	Segment 2	Yes	Yes				0-255 → select shape width			
33	26	x Bump	No	Yes				0-255 → select macro offset	Linear fade		
34	27	Image	No	Yes							
35	28	Bumping section	Yes	Yes							
36	29	Ramp by 6	Yes	Yes				0-255 → select shape width	Linear fade and wake length		
37	30	Ramp by 4	Yes	Yes							
38	31	Left/Right scrolling bar	Yes	Yes							
39	32	Up/Down scrolling bar	Yes	Yes							
40	33	Bar 3	Yes	Yes				0-255 → select macro offset	Linear fade		
41	34	Vertical arc 1	No	Yes							
42	35	Vertical arc 2	Yes	Yes							
43	36	Horizontal arc 1	No	Yes							
44	37	Horizontal arc 2	Yes	Yes							
45	38	Mirrored pixel	Yes	Yes				0-255 → select shape width	Linear fade and wake length		
46	39	Pixel animation 1	Yes	Yes							
47	40	Pixel animation 2	Yes	Yes		N.a.					
48	41	Pixel animation 3	Yes	Yes							
49	42	Pixel animation 4	Yes	Yes							
50	43	Pixel animation 5	Yes	Yes							
51	44	Semi arc (Ramp /+)	Yes	Yes							
52	45	Bumping arc section	Yes	Yes				0-255 → select macro offset	Linear fade		
53	46	Pixel animation 6	Yes	Yes							
54	47	Vertical ramp by 2	Yes	Yes				0-255 → select shape width	Linear fade and wake length		
55	48	Following pixel by 2	Yes	Yes							
56	49	Syncopation	Yes	Yes				0-255 → select macro offset	Linear fade		
57	50	Bumping 1	Yes	Yes							
58	51	Bumping 2	Yes	Yes							
59	52	Bumping 3	Yes	Yes							
60	53	Vertical pixel scrolling	Yes	Yes				0-255 → select macro width	Linear fade and wake length		
61	54	Random vertical section	Yes	Yes				0-255 → select random distribution	Linear fade		
62	55	Random central section	Yes	Yes		Yes					
63	56	Random ring 2	Yes	Yes		Yes					
64	57	Random ring 3	No	Yes		Yes					
65	58	Random ring 1+3	Yes (*2)	Yes		Yes					
66	59	Random ring 2+3	Yes (*2)	Yes		Yes					
67	60	Single pixel ring 1	Yes	Yes				0-255 → select the number of rotating	Linear fade and wake length		
68	61	Single pixel ring 2	Yes	Yes							
69	62	Single pixel ring 3	No	Yes		N.a.					
70	63	Spiral	Yes	Yes				0-255 → select macro width	Linear fade and wake length		
71-255	64					N.a.		N.a.	N.a.		N.a.

• SHAPE FADE

BIT	EFFECT
246-255	Smooth, fading curve with automatic gamma *
245	Smooth, fading curve gamma 2
243	Smooth, fading curve gamma 1,986
244	Smooth, fading curve gamma 1,993
⋮	
18	Smooth, fading curve gamma 0,513
17	Smooth, fading curve gamma 0,506
16	Smooth, fading curve gamma 0,5
0-15	Snap

• SHAPE TRANSITION

BIT	EFFECT
255	4 sec
⋮	
216	3 sec
⋮	
171	2 sec
⋮	
113	1 sec
⋮	
73	0,5 sec
⋮	
5	100 ms
0-4	No fade

• SHAPE RGBW
SHAPE DIMMER
BACKGROUND DIMMER



BIT	EFFECT
255	LED ON
⋮	
0	LED OFF

• BACKGROUND SELECT
Alela K10 - Background select

BIT	EFFECT
255	Mirror effect
16-254	No selection
⋮	
15	Ring 2 + Ring 3
14	Pixel 1 + Ring 2 + Ring 3
13	Pixel 1 + Ring 2
12	Pixel 1 + Ring 3
11	Ring 3
10	Ring 2
9	Pixel 1
8	No selection

Alela K20 - Background select

BIT	EFFECT
255	Mirror effect
24-254	No selection
⋮	
23	Pixel 1 + Ring 2 + Ring 4
22	Pixel 1 + Ring 3 + Ring 4
21	Ring 2 + Ring 4
20	Pixel 1 + Ring 3
19	Ring 2 + Ring 3
18	Pixel 1 + Ring 4
17	Ring 3 + Ring 4
16	Ring 2 + Ring 3 + Ring 4
15	Pixel 1 + Ring 2 + Ring 3 + Ring 4
14	Pixel 1 + Ring 2 + Ring 3
13	Pixel 1 + Ring 2
12	Ring 4
11	Ring 3
10	Ring 2
9	Pixel 1
8	No selection

A.LEDA B-EYE K10 & K10 EASY

LED reference number for pixel mapping

TILT: channel 16 @ 200 bit

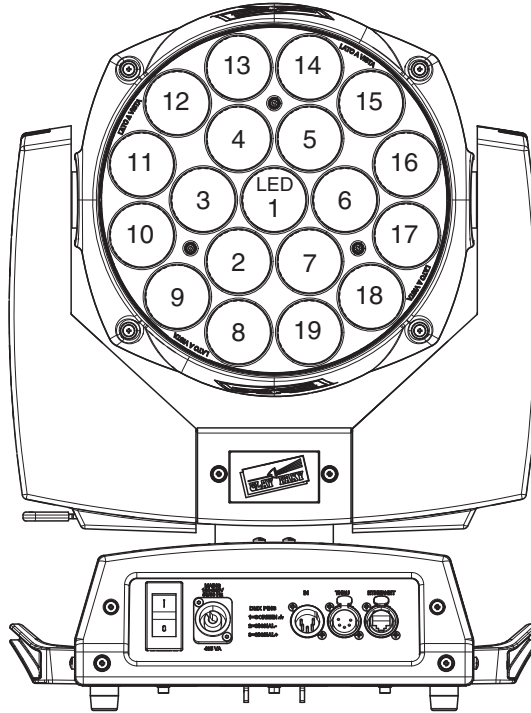

A.LEDA B-EYE K20

LED reference number for pixel mapping

TILT: channel 16 @ 200 bit

