

MICROPACK - MICRORACK 25

Instruction Manual



ADB
Lighting Technologies



ADB
Lighting Technologies

Summary

Generalities - Safety	2
Description	3
Front Panel	4
Product Description	6
Menu	17
Warning messages (important !)	26
Maintenance functions	27
Putting into Operation	30
Electrical characteristics	37
Mechanical characteristics	38
Installation of the Analogue Inputs kit	39
Maintenance, spare parts	42
Drawings	43

MICROPACK

MICRORACK 25

Delivery - Unpacking

Upon delivery of your equipment, open the packaging carefully and examine the dimmer unit.

If you observe any damage, contact the shipping company immediately, and have your complaint duly recorded. You may rest assured that your equipment left the factory in perfect condition.

Check whether what you have received is in conformity with the delivery notice, and whether the notice is in conformity with your order.

In the event of any error, contact your shipper immediately to clarify the situation and receive full satisfaction.

If you find nothing wrong, replace the material in the packing and store it in a warm place, away from dust and humidity, while awaiting final installation.

Never leave the material on the worksite under any circumstance.

Generalities - Safety

The MICROPACK and MICRORACK 25 are professional fully digital dimmers built in accordance with European safety standards EN 60950 and EN 60204.

It is a Class I equipment designed and manufactured to EN 60950 and requires imperatively a safety earth connection in compliance with local regulations.

To prevent any risk of electric shock, do not remove any cover or part of the enclosure.

Access to internal parts is not required for normal operation.

Refer servicing to skilled and trained service personnel exclusively.

Disconnect from the power supply prior to opening for inspection or service.

WARNING ! LETHAL VOLTAGES ARE PRESENT INSIDE

Connection to an inappropriate power source may irreversibly damage the dimmer unit, it is the user's responsibility to use it for its intended purpose and to check the equipment connected to it.

The MICROPACK and MICRORACK 25 are professional equipment developed with the simplicity of use in mind.

However, to obtain full benefits of the safety measures, the equipment shall be installed and serviced by skilled and trained personnel exclusively.

Important Notice for Power Cables

Power supply cables and connectors are an important part of your equipment and contribute to its safety.

- always use an isolator or main circuit-breaker or RCD (use the TEST button), or main fuses to interrupt the link; never pull on the cable
- do not damage the cable nor the connectors in any way, check them at each installation or at regular intervals in a permanent installation
- do not tie together power supply cables and signal cables

MICROPACK MICRORACK 25

Description

All-digital dimmer rack for general purpose applications, combining high quality with low cost and above average performance.

High density unit for applications in stage and architectural lighting whenever space, cost and reliability are the prime considerations.

MICROPACK - 6 x 2.3 kW - Portable



Weight and dimensions

Dimensions (mm)	350 x 445 x 133
Net Weight (kg)	14
Packing (mm)	460 x 595 x 245
Gross Weight (kg)	16

MICRORACK 25 - 12 x 2.3 kW - Rack-mount



Suitable for insertion in touring racks and for fixed installations in MEMORACK 180 cabinets or 19" racks.

Weight and dimensions

Dimensions (mm)	484 x 500 x 133
Net Weight (kg)	17
Packing (mm)	540 x 595 x 245
Gross Weight (kg)	19

Main Features

- 3-key keypad, 4-character LED display and user-friendly menu for easy access to all dimmer functions
- local test of a dimmer (steady or chaser)
- 10 dimmer laws selectable per dimmer
- fade smoothing (4000-step resolution)
- last lighting cue maintained in case of DMX signal interruption
- permanent storage of all programmed data
- protection circuitry against accidental 400 V wiring
- local status reporting: 400 V wiring errors - over-temperature - processor check - presence of DMX signal - DMX and analogue control levels
- first dimmer address selection
- storage of a lighting cue
- high quality, low noise fan(s) for effective cooling with automatic fan-stop
- overtemperature protection through gradual dimmer fade out

Technical Specifications

- power supply: 230 V / 400 V Star - 3NPE (TN-S)
- MICROPACK: individual protection by 1P-HRC fuses 6 x 32 mm, with "fuse ok" neon indicator; optional 1P+N protection
- MICRORACK 25: individual protection by 1P-HRC fuses 10 x 38 mm, with "fuse ok" neon indicator and slot for a spare fuse; optional 1P+N protection
- suitable for continuous duty at 6 x 10 A or 12 x 10 A at 35°C (2.2 kW at 220 V, 2.4 kW at 240 V)
- DMX 512/1990 (XLR5) and optional analogue inputs (DB25)
- galvanic isolation on the DMX input
- meets all applicable European standards and is labelled CE

Architectural Applications

The analogue input option allows remote control by means of

- analogue control desk (0/+10V)
- 3-position selector switch (up - down - steady), one switch can control one or several dimmers

MICROPACK

MICRORACK 25

Front Panel

MICROPACK - 6 x 2.3 kW - Portable



Indicators :

- Presence of DMX signal
- Microprocessor running
- Error messages: 400 V supply wiring error, temperature warning, fan failure, DMX error, ...
- Display of DMX or analogue levels in %

Control protocols

- digital: DMX 512/1990 on XLR5 connectors
- connector pin-out silk-screened on the front panel

Options

- 6 Analogue inputs for MICROPACK, DB25-S receptacle
- 12 Analogue inputs for MICRORACK, DB25-S receptacle

MICRORACK 25 - 12 x 2.3 kW - Rack



Protections

- MICROPACK:
 - MCB single pole 10A curve C, 6kA breaking capacity
- MICRORACK 25 :
 - single-pole fuses, 10 x 38 mm, HRC (100 kA), gL, gG 8A or MCB single pole 10 A curve C, 6 kA breaking capacity
 - Supply and "fuse OK" indicator per dimmer
 - A spare fuse can be stored in each 10 x 38 mm fuse holder
 - Protection circuitry against accidental 400 V wiring errors
 - Overtemperature protection (gradual fade-out)
 - Fan failure detection

Option

- dimmer protection 1P+N (fuses 10 x 38 mm) instead of 1P
- 8A gL, gG, 100kA continuous use at 10A

Note:

Standard MICROPACK and MICRORACK 25 versions are supplied without supply cable and XLR5 plugs

Power Supply Connection

MICROPACK

- Terminal strip, 3-phase + N + PE
- Cable clamp for Ø 20 mm cable

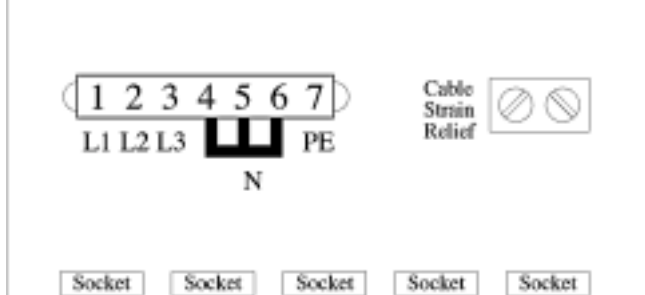

Mains Supply

- Star mains supply 3NPE (TN-S), 400 V, 50 / 60 Hz
- Single-phase operation possible (single-pole protected)

MICRORACK 25

- Terminal strip, 3-phase + N + PE
- Cable clamp for Ø 20 mm cable

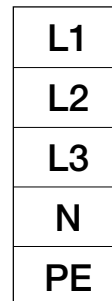

Mains Supply

- Star mains supply 3NPE (TN-S), 400 V, 50 / 60 Hz

MICROPACK MICRORACK 25

Standard Outlet Panels

MICROPACK

- supply : PG

Outputs

6 x twin NF/CEBEC

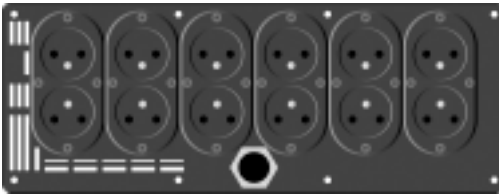

6 x twin Schuko

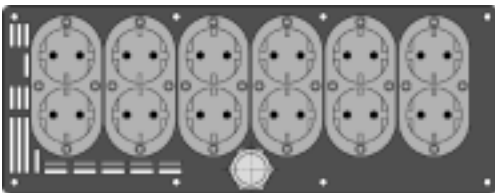

6 x UK 15 A

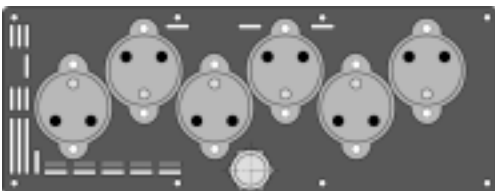

6 x triple Swiss

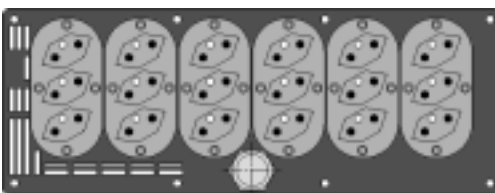

6 x CEE 16 A (P17)



MICRORACK 25

- supply : PG

Outputs

2 x AMP (12P - 15A)



2 x Socapex 419

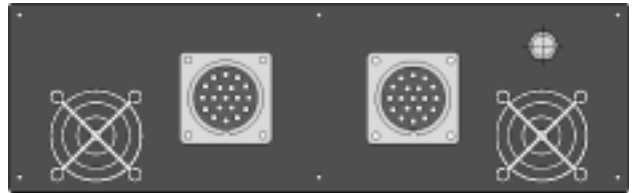

2 x twin Wieland ST18/3 (Series 120 V or parallel 230 V)



Compatible for use in MEMORACK 180
supply : Harting outputs : 2 x AMP (12P - 15A)



DMX connector (IEEE488) at the rear

Output wiring

- the versions with Socapex and Wieland ST18/3 outputs provide P+N+PE per dimmer
- the versions with 1P+N wiring and AMP outputs provide P+N per dimmer; the wiring of PE to the loads will be external to the MICRORACK
- the versions with 1P wiring and AMP outputs provide P per dimmer; the wiring of N and PE to the loads will be external to the MICRORACK 25

MICROPACK

MICRORACK 25

Product Description

Digital dimmers

MICROPACK and MICRORACK 25 are members of a family of fully digital dimmers, using advanced microprocessor control and an Application Specific Integrated Circuit (= custom chip) designed by ADB.

Digital control offers stable, accurate and repeated performance over time, without the periodical recalibration required by dimmers with analogue circuitry.

The very straightforward menu-driven set-up provides maximum flexibility for a wide range of applications.

In a dimmer equipped with the Analogue Input option, the analogue control signals are converted to a digital signal by the DAC (Digital to Analogue Converter), and are further processed as digital data.

The analogue and the DMX levels are merged for every dimmer, on a "highest takes precedence" (HTP) basis.

Example :

- dimmer - DMX control desk at 70 %
- analogue control desk at 50 %
- dimmer output level will be 70 %

- dimmer - DMX control desk at 20 %
- analogue control desk at 80 %
- dimmer output level will be 80 %

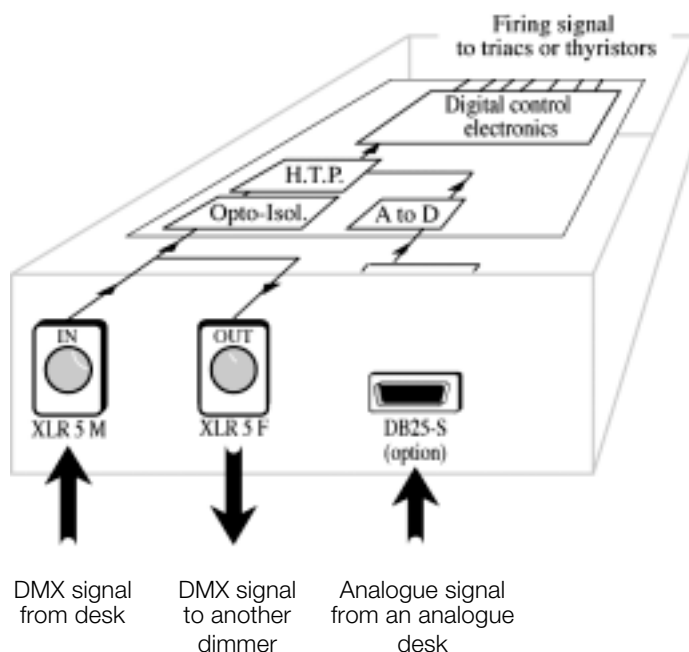

MICROPACK

MICRORACK 25

Ratings

MICROPACK is suitable for continuous duty at 6 x 10 A and 35°C ambient temperature (6 x 2.300 W at 220 V and 6 x 2.400 W at 240 V).

MICRORACK 25 is suitable for continuous duty at 12 x 10 A and 35°C ambient temperature (12 x 2.300 W at 220 V and 12 x 2.400 W at 240 V).

When totalling up the load to a dimmer, one should include the losses in the cabling and, if applicable, the losses in the transformer.

The factory-fitted protections have carefully been selected for optimum protection of the semiconductors and the cabling, for maximum safety and reliability.

Do not use types other than supplied for the dimmer.

The factory-supplied fuses and spare-parts are selected for continuous operation at 10 A. Fuses are labelled at lower values (e.g. 8 A) and the fusing point is at + 25%.

Loads

The use of oversized power semiconductors and an appropriate gate firing technique makes your dimmer suitable for a wide range of resistive and slightly inductive loads, including tungsten lamps, low-voltage lamps with a suitable transformer, fluorescent lamps with a suitable ballast.

The following precautions improve the reliability and performance of dimmer systems in general:

- every low-voltage transformer must be protected by its own primary fuse
- use preferably more than one lamp on the secondary of a low-voltage transformer
- power-factor correction capacitors, such as supplied with some fluorescent lamp fixtures, should not be connected to a dimmer; they must be connected to the mains

Packaging : Portable, Rack-Mount

The MICROPACK is equipped with a carrying handle.

- never use the carrying handle to suspend the MICROPACK
- the MICROPACK can be secured e.g. by means of safety cables.
Four slots are provided, suitable for 6 mm safety hooks.

A retrofit kit is available with two mounting brackets for standard 19" racks.

Rack-mounting: when mounted in a 19" rack, the MICROPACK and MICRORACK 25 must be supported. If desired, the same brackets can be used at the rear (socket panel).

Rubber feet

The MICROPACK is equipped with eight rubber feet, for horizontal or vertical use. The MICROPACK will easily be stacked thanks to slots in the top flange.

Cooling

Your dimmer is equipped with a forced ventilation system, with one or two long-life, low-noise, high performance fan. This allows continuous use at full rated load. For MICROPACK, air intake apertures are on the socket panel, and the exhaust aperture is on the front panel. Do never obstruct these apertures !

For MICRORACK 25, air intake is on the front panel, and two fans are placed on the rear panel. Do not block the airflow !

The automatic thermal protection scheme is detailed in "Miscellaneous - Gradual Shutdown".

MICROPACK

MICRORACK 25

Supply connections

Type of mains supply network

Before you connect electrical equipment, you must verify that it is adapted to the mains system at your venue.

If in doubt consult the electrician or the utility company.

The standard dimmer is suitable for a three-phase 3NPE, 400 V, 50 Hz and 60 Hz, TN-S system (three phase wires + Neutral wire + Earth wire; Neutral directly connected to Earth).

The rated voltage between phase and Neutral is 230 V. The operating voltage must lie between $230\text{ V} \pm 14\%$ (198 V to 264 V).

The dimmer protections are single-pole, in the Live wire, as required for a three-phase TN-S supply. 1P + N protections are optional.

Under some conditions, the dimmer can be operated on a single-phase supply. Details are described in "Single-phase conversion kit"

Protection on the supply side

The power outlet which feeds the dimmer and the supply cable must be adequately protected against overload and short-circuit by the installation; verify the current edition of the applicable wiring regulations.

Please also refer to "Supply Cable", and to "Electrical Characteristics".

Supply terminals

All connections should be performed by a qualified electrician.

The supply terminals are suitable for cables up to 4 mm² (MICROPACK) or 6 mm² (MICRORACK 25).

The colour code is blue for Neutral and Yellow/Green for PE.

The top cover must be removed to gain access to the supply terminals.

How to remove the top cover

- always disconnect the power supply before you remove the cover
- please refer to the sketch for the position of the ten screws which secure the top cover. Do not remove any other screws !
- when closing the dimmer, carefully position the special washers (position 2)

MICROPACK

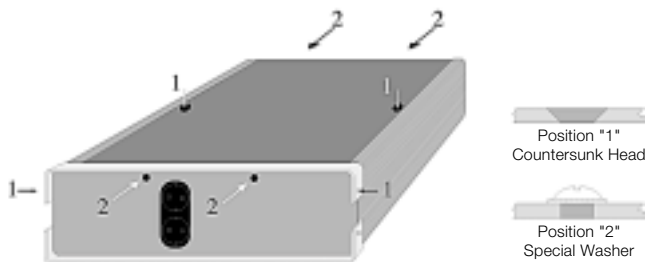

MICRORACK 25



MICROPACK MICRORACK 25

Supply cable

The size of the Neutral wire must at least be equal to the size of the phases; reduced-size Neutral wires are DANGEROUS and are NOT allowed.

All supply cables and extension cables should have all conductors under the same sleeve, in order to reduce unwanted interferences to audio and video equipment.

The supply cable should be sized for the rating of the dimmer unit:

MICROPACK

- 20 A per phase for three-phase star operation (3 x 400 V + N);
e.g. cable 5 x 4 mm², EPR, 85 Celsius
- 60 A for single-phase operation (230 V + N);
e.g. cable 3 x 10 mm², EPR, 85 Celsius

MICRORACK 25

- 40 A per phase for three-phase star operation (3 x 400 V + N);
e.g. cable 5 x 6 mm², EPR, 85 Celsius

Cables for lower current ratings are not allowed unless the protection devices in the installation (supply fuses or supply circuit-breaker) are selected accordingly.

Spade cable terminals are required for connection to the three-phase terminals.

Spade terminals suitable for cables up to 10 mm² are included in the single-phase conversion kit.

Operation on a Star system (3 x 400 V + N + Earth)

MICRORACK 25



Single-phase conversion kit for MICROPACK

The MICROPACK can under some circumstances (see Warning below) be used on a single-phase supply. L1, L2 and L3 are linked for single-phase operation; the Live of the supply system is connected to terminal 2 (central position).

Terminals 4, 5 and 6 are always linked; the Neutral of the supply system is connected to terminal 5 (central position).

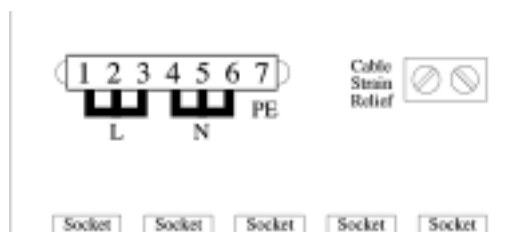

WARNING

The MICROPACK (TN version) will operate on a single-phase supply, but the user must verify whether single-pole protections are allowed by the applicable wiring regulations.

The dimmer will operate reliably up to its full rated load (60 A) at 35°C. The actually available power may be limited by the power supply (cable size, supply fuse rating, supply mcb rating).

MICROPACK

MICRORACK 25

Control Connections

Two lighting control desks can simultaneously control your dimmer unit: one DMX512 and one Analogue (Analogue Inputs are optional). The actual dimmer output will be the highest of the two levels (Highest Takes Precedence, HTP), as described in the example on page 5.

DMX512/1990

DMX512 (USITT) is internationally the most widely accepted communication standard for lighting control equipment. The standard is issued by the USITT (U. S. Institute of Theatre Technology); the suffix 1990 indicates the latest issue.

The DMX512 signal is a Digital MultipleXed control signal, suitable for the digital transmission of the levels of up to 512 dimmers.

Electrically it uses the RS-485 (EIA-485) standard, which states: wire pairs + screen; maximum 32 receivers on a line; cable length without reamplification max. 300 m; no splitting or T-junctions. Transmission rate is high (250 kbit/s). Dimmer levels are sent in bytes of 8 bits (256 possible levels).

DMX512 network

The MICROPACK is fitted with two XLR5 connectors (IN and OUT) for a daisy-chain DMX512 network (see example 1). IN and OUT are wired through internally. Used pin numbers are indicated on the front panel and in the wiring diagrams at the end of this manual.

Termination of the DMX line

The DMX OUT of the last dimmer unit on the daisy-chain must receive a Termination Plug. This Termination Plug is an XLR5 receptacle with a small resistor of 120Ω 0,33 W soldered between pins 2 and 3. A diagram is shown at the end of this manual.

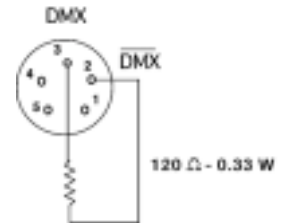

Dimmer Address

The DMX address of the first dimmer in the unit is set by the address item in the Menu List. The addresses of the other dimmers follow.

Example :

if the address is set at 019, then the six dimmers in the MICROPACK will be numbered 19 (first dimmer) through 24 (last dimmer).

The DMX512 network

The DMX512 network starts from the lighting control desk. A first cable runs from the DMX OUT of the control desk to the DMX IN of the nearest dimmer unit. The daisy-chain continues by means of a second cable, connecting DMX OUT to DMX IN of the next dimmer unit. This daisy-chain is continued through all the dimmer packs in the system. The DMX IN and DMX OUT connectors are wired in parallel, so continuity of the daisy-chain is always provided. The continuity and quality of the DMX signal will not be affected when the dimmer unit is switched off, or when a failure occurs.

Opto-isolation

The DMX512 input of your dimmer unit is equipped with optocoupler isolation. This provides galvanic isolation between the DMX network and the microprocessor electronics in the dimmer unit. This is an important safety feature: should for example the DMX512 network come in contact with mains voltage, then the internal electronics of the dimmer unit will remain isolated from those dangerous voltages. Such accident could occur for example when cables are severely damaged or crushed, or when an isolation fault occurs in a control desk which has no opto-isolation in its output.

MICROPACK MICRORACK 25

Example 1: four MICROPACKs (24 dimmers) controlled by a lighting control desk

Address set at 007
Dimmers : 7 through 12

Address set at 019
Dimmers : 19 through 24

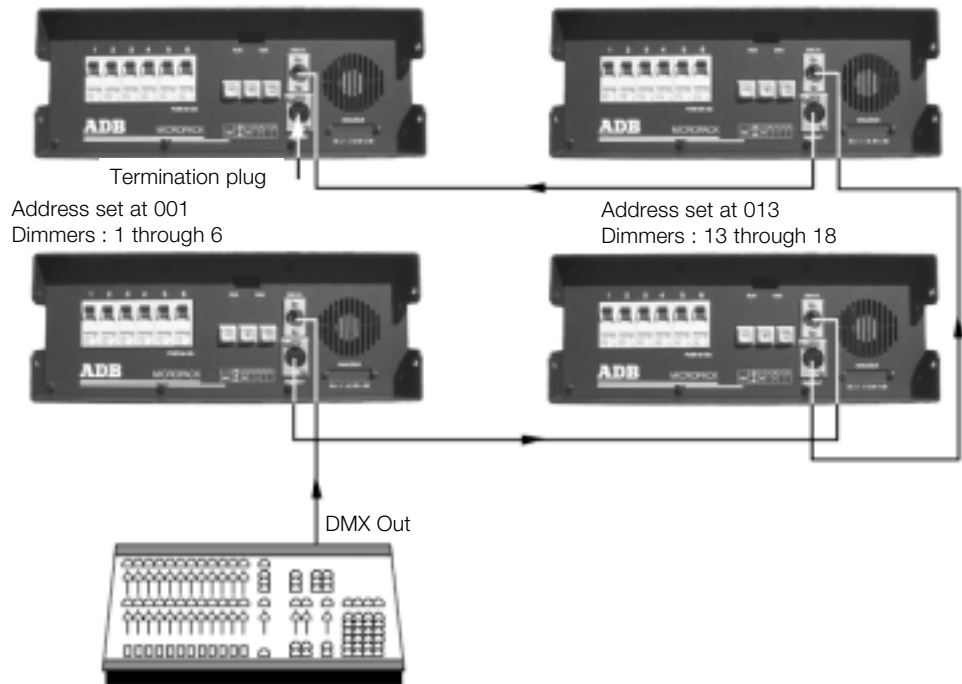

How to lay-out the DMX512 cables

- the dimmer units can be daisy-chained in any order (see example 1).
- the last unit on the DMX line must be equipped with a Termination Plug.
- do not use microphone cable. Use dedicated cable, suitable for data transmission.
- the overall length of the DMX cables (sum of the length of the individual cables) is very important.

We recommend that it should not exceed 250 m. Longer cable runs are likely to reduce the quality of the DMX signal, which may result in unpredictable results.

For cable runs exceeding 250 m an active amplifier is required, such as ADB's DATA BOOSTER. A 250 m cable run can be connected to each active output of the DATA BOOSTER.

- T-splitting is not allowed. If the DMX network must fan out in different directions, then an active splitter is required, such as ADB's DATA BOOSTER.
- the DMX512 standard states that max. 32 receiver units may be connected to one transmitter. So up to 32 dimmer units (or DMX receivers) can be connected to a lighting control desk, or to an active output of a DATA BOOSTER/SPLITTER.
- do not run DMX512 cables (or Analogue control cables) together with power cables
- for further information, please refer to the data sheet of the DATA BOOSTER.

MICROPACK MICRORACK 25

DMX Network - Application Examples

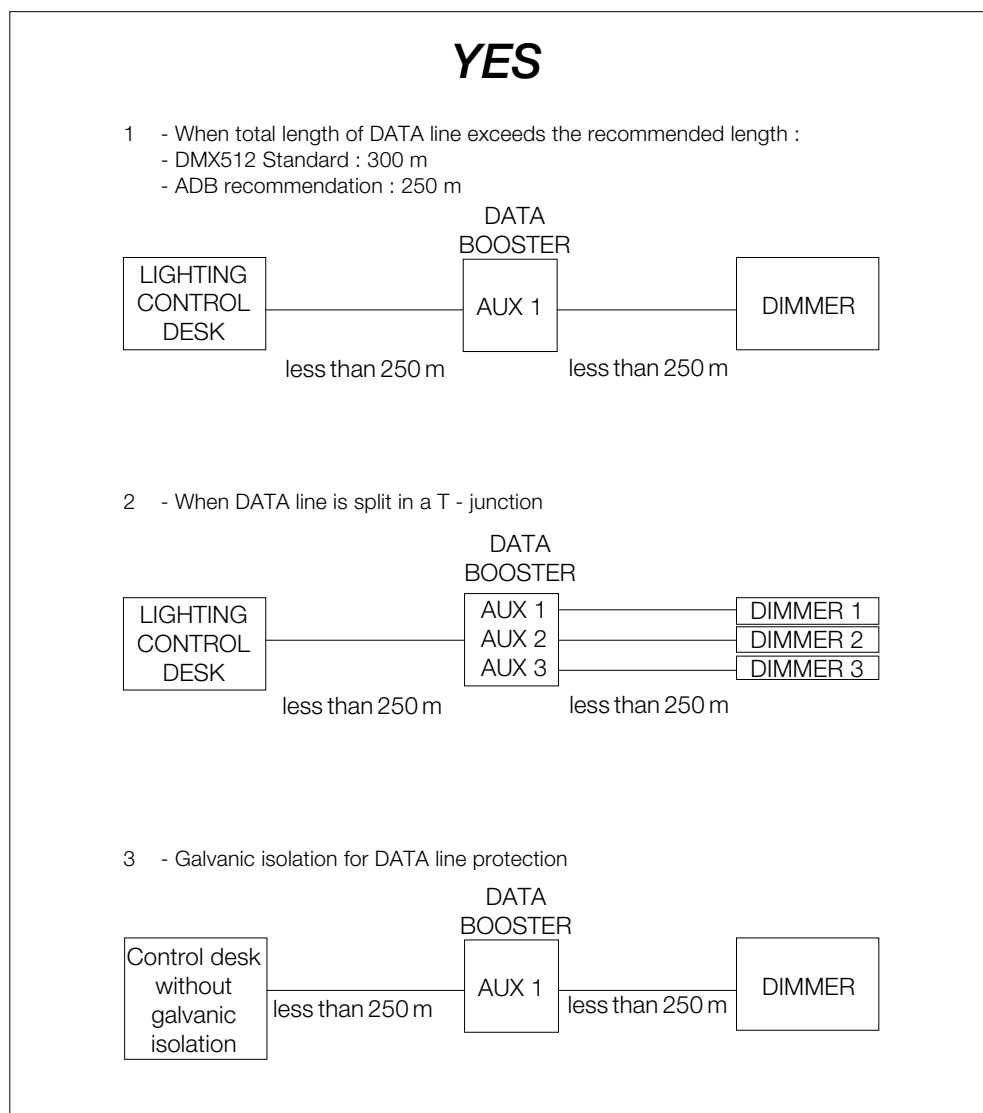
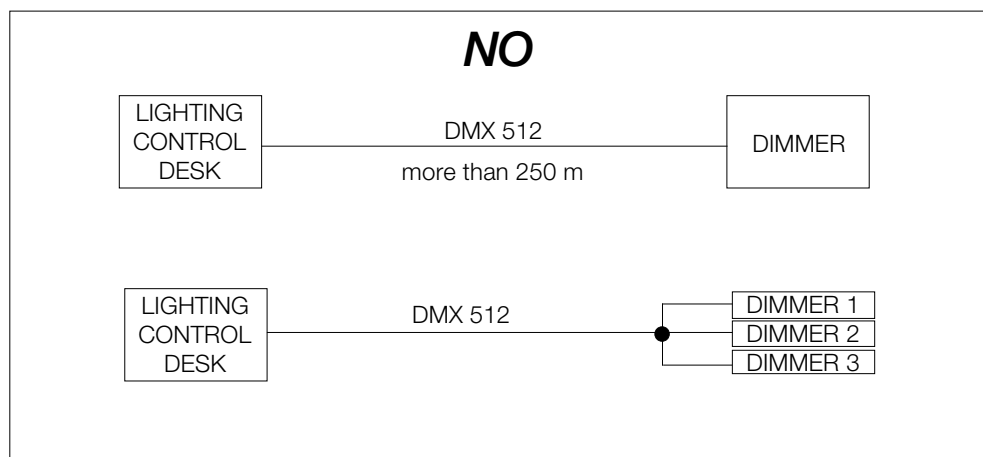

MICROPACK MICRORACK 25

Example 2 : one MICROPACK, with Analogue Input Option, controlled by an analogue output desk

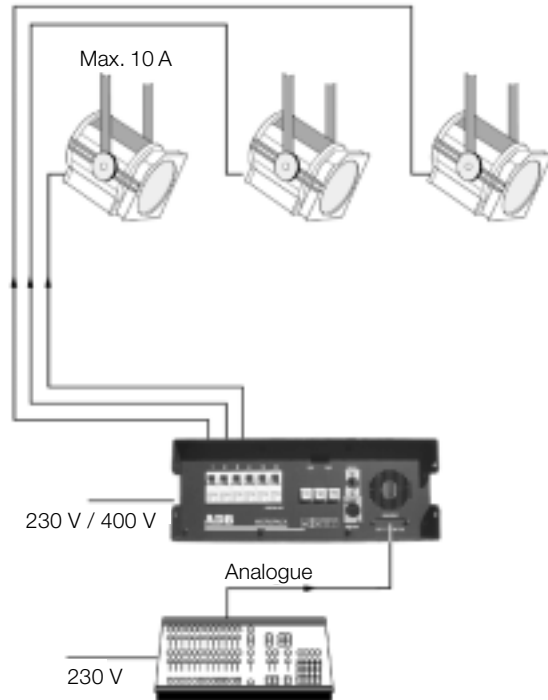

Example 3 : one MICROPACK, with Analogue Input Option, controlled simultaneously by an analogue output desk and a multiplexed desk (Highest Takes Precedence)

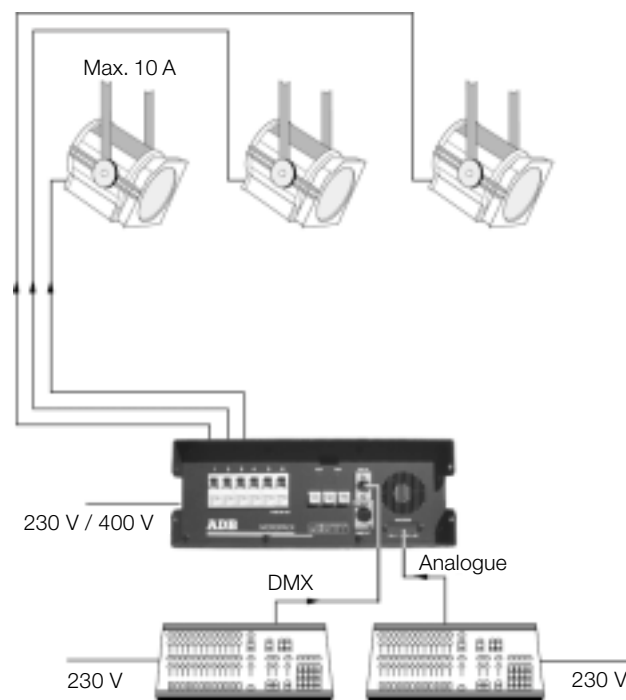

MICROPACK

MICRORACK 25

Example 4 : one MICROPACK controlled by a DMX desk, which also controls DMX colour scrollers (GELBUS)

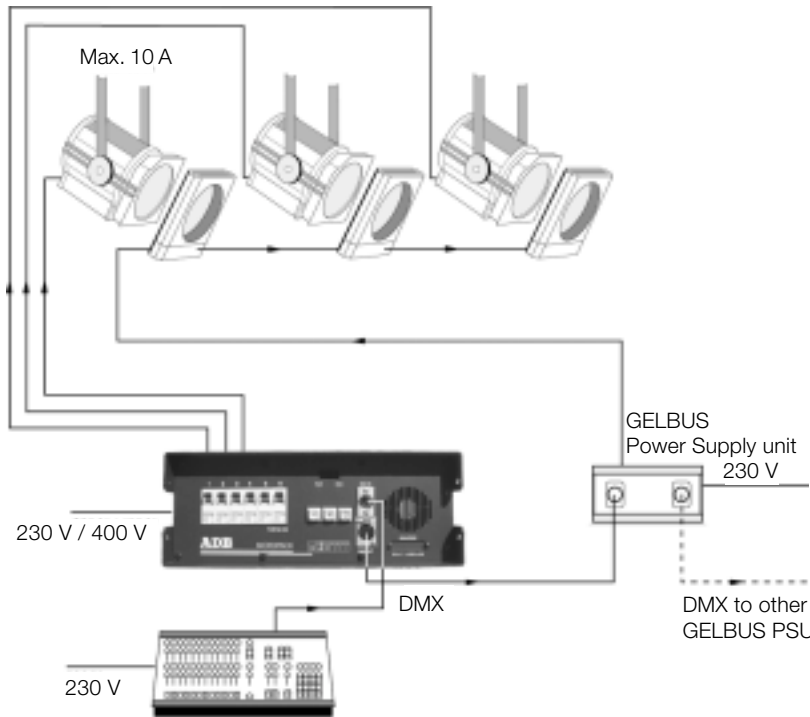

Analogue inputs

Your MICROPACK / MICRORACK 25 can be equipped with Analogue Inputs, in which case it can be controlled by analogue control signals, 0/+10V or 0/+370 μ A (filtered).

If the Analogue Inputs were factory-installed, they were set for 0/+10V operation; you can easily perform the conversion to 0/+370 μ A yourself. See below for the detailed procedure.

The Analogue Inputs connector is a DB25-S receptacle, on the front panel.

The pin allocation is indicated on the front panel of your dimmer unit. The following table shows the pin allocation for all the connectors, including P3 and P4 on the Analogue Inputs board.

		DB-25 S	internal (P3, P4)
control dimmer	1	pin 1	pin 1
control dimmer	2	pin 2	pin 3
control dimmer	3	pin 3	pin 5
control dimmer	4	pin 4	pin 7
control dimmer	5	pin 5	pin 9
control dimmer	6	pin 6	pin 11
control dimmer	7	pin 7	pin 13
control dimmer	8	pin 8	pin 15
control dimmer	9	pin 9	pin 17
control dimmer	10	pin 10	pin 19
control dimmer	11	pin 11	pin 21
control dimmer	12	pin 12	pin 23
		pin 13 through 24 not connected	
0 V		pin 25	pin 24 and 26

Internal setting for Analogue Inputs

- setting for 0/+10 V operation: the ribbon cable with the front-panel DB-25-S Analogue receptacle is plugged into P3 on the Analogue Input board PCB 1336
- setting for 0/+370 μ A operation: the ribbon cable with the front-panel DB-25-S Analogue receptacle is plugged into P4 on the Analogue Input board PCB 1336
- W1 on PCB 1336: jumper removed, or placed between pin 2 and pin 3
- W2 on PCB 1336: jumper removed, or placed between pin 2 and pin 3

Analogue Inputs : selection 0/+10 V or 0/370 μ A

To convert your dimmer unit from 0/+10 V setting to 0/+370 μ A please refer to qualified personnel:

- disconnect the dimmer unit from the mains
- remove the top cover, see the sketch in the Supply Connections Chapter
- touch the aluminium heatsink to discharge electrostatic build-up
- identify on the small Analogue Inputs board connector P3, labelled 0->10V
- remove the 25-wire flat (ribbon) cable from that connector
- connect the 25-wire flat (ribbon) cable to connector P4, labelled 0->370 μ A
- secure the connector
- close the cover, verify the presence of the special washers

MICROPACK

MICRORACK 25

Front-panel Controls

MICROPACK - 6 x 2.3 kW - Portable



MICRORACK 25 - 12 x 2.3 kW - Rack



Phase Distribution (MICROPACK)

The dimmers are supplied from alternating phases :

- dimmer 1 is supplied from phase L1
- dimmer 2 is supplied from phase L2
- dimmer 3 is supplied from phase L3
- dimmer 4 is supplied from phase L1
- dimmer 5 is supplied from phase L2
- dimmer 6 is supplied from phase L3
- the microprocessor electronics are supplied from phase L1

Phase Distribution (MICRORACK 25)

The dimmers are supplied as follows :

- dimmers 1, 2, 3, 4 are supplied from phase L1
- dimmers 5, 6, 7, 8 are supplied from phase L2
- dimmers 9, 10, 11, 12 are supplied from phase L3
- the microprocessor electronics are supplied from phase L1

Status Indicators

Run : the microprocessor is operational if this LED flashes approx. once per second.

DMX : this LED indicates the presence of a multiplexed signal on the DMX input; this can also be used to locate short-circuits in your data cables

MENU

Operation of your dimmer is very straightforward, by means of the three control keys, the alphanumeric display, and a simple Menu.

Principle of operation

By depressing the + or - keys, you can display the list of subjects or 'Menu items'. When you reach the item of interest, you depress the YES key.

Simplicity tailored to your needs

The number of items on the Menu list can be adapted by the user, so that the functionality of the dimmer can match the level of experience of the individual user.

Three levels of display are available: the higher the selected level, the more features are added to the Menu list. The three levels are known as Menu 1 through Menu 3.

Menu 1

Menu 1 opens up one basic function:

- you can set the DMX address of the first dimmer

Menu 2

Menu 2 is for the user interested in the full range of features

- the function of Menu 1, and additional to that
- you can test dimmers individually
- you can start an automatic dimmer test (chaser)
- you can set dimmer laws per dimmer
- you can use the memory
- you can display incoming control levels (DMX512 and Analogue)

Menu 3

The maintenance Menu, Menu 3, is not required for day-to-day use. Its functions are intended for maintenance engineers only. Details of Menu 3 are included in the Maintenance chapter of this manual.

Default display

The address of the first dimmer is automatically displayed after a certain time.

MICROPACK MICRORACK 25

“Hidden” items are not disabled

Menu items that are hidden are still active.

Example: a more experienced operator may use Menu 2 to program the dimmer laws, and then set the dimmer unit to Menu level 1. The next user will then have the DMX address selection at his/her disposal, but with the dimmer laws still active as programmed.

How to select the Menu level

Example: you want to modify the dimmer law, so you need access to Menu 2.

- depress + or - until **Menu**
- depress **YES**
- depress + or - until **Men2**
- depress **YES**
- the display returns to the main Menu **Menu**

You now have access to the functions of Menu 2

Non-volatile memory

All parameters are stored in the dimmer unit for an infinite time. No battery needs to be maintained.





Dimmer address

The DMX address

Every unit on the DMX network receives on its DMX input a digital signal which contains the dimmer levels for all the dimmers of the system. The Dimmer Address function defines which dimmer levels are relevant for the dimmers in the MICROPACK / MICRORACK 25. The number which is set via the Addr menu is the 'DMX address' of the first dimmer. The other dimmers will respond to the next DMX addresses.

Example : the MICROPACK's Address is set to 19 (display: A19). The first dimmer's address is 19, dimmer No. 2 has address 20,... dimmer No. 6 has address 24.

Setting of the dimmer address

This function is included in all Menu levels.

Example: the DMX Address is currently set at 1, and you wish to set it to 19:

- select Menu 1 or Menu 2, as indicated above
- depress + or - until **Addr**
- depress **YES**
- the display shows **A 1**
- depress + or - until **A 19**
- depress **YES**
- the display returns to the main Menu list **Addr**

Dimmer test

Auto dimmer test - chaser

This function is included in Menu 2.

With the Auto function, you can run an automatic chaser through all the dimmers of the unit. Each dimmer in turn will ramp up to 70%, and then fade out to Off. The cycle through the channels takes approximately 15 seconds. The chaser will run until you restore normal operation (control via DMX and/or Analogue inputs), by depressing + or -.

To start the chaser

- select Menu 2, as indicated above
- depress + or - until **Auto**
- depress **YES**
- the display shows dimmer number and dimmer level.

To end the chaser and to restore normal operation:

- depress + or -
- the display returns to the main Menu **Auto**



MICROPACK MICRORACK 25

Individual dimmer test

This function is included in Menu 2.

With the Test function you can select one of the dimmers and set it at a preset level of 70% or a level of your choice.

In the Test mode only the dimmer under test will be On; the other dimmers in the dimmer unit will be Off. DMX and Analogue inputs will be discarded.

To restore normal operation (control via DMX and/or Analogue inputs), leave the Test mode.

Example 1 : to test dimmer 3 at 80%

- select Menu 2, as indicated above
- depress + or - until **Test**
- depress **YES**
- the display shows **T.1?**
- depress + until **T.3?**
- depress **YES**
- the display shows (for example) **3:70** dimmer 3 is now on, at 70%
- depress + or - until **3:80**

To leave the Test mode

- depress **YES**
- the display shows (for example) **T.4?**
- depress + or - until **Test**

Example 2 : test all dimmers, one after the other, at 70%

If you wish to test the next dimmer at the same level, then simply depress YES twice

- select Menu 2, as indicated above
- depress + or - until **Test**
- depress **YES**
- the display shows **T.1?**
- depress **YES**
- the display shows (for example) **1:80** dimmer 1 is now on, at 80%
- depress + or - until **1:70** dimmer 1 is now on, at 70%
- depress **YES YES**
- the display shows **2:70** dimmer 2 is now on, at 70%
- depress **YES YES**
- the display shows **3:70** dimmer 3 is now on, at 70%
- etc.

To end the Test mode and to restore normal operation

- depress **YES**
- the display shows (for example) **T.4?**
- depress + or - until **Test**

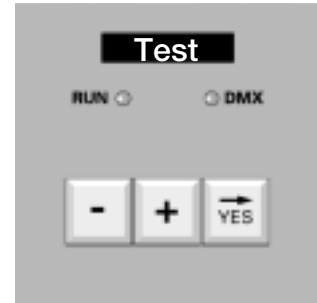

MICROPACK MICRORACK 25

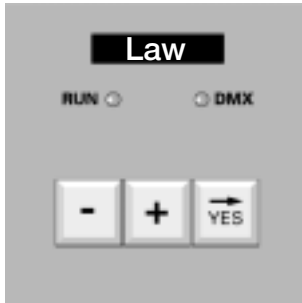

Dimmer law

The dimmer law gives the relation between the output voltage (Volts rms, usually in % of the supply voltage), and the control signal (usually given in %).

The Linear law, for example, will give an output voltage which is linear with (proportional to) the control signal. If the control level is 70%, then the output (rms) voltage will be 70% of the supply voltage.

Your dimmer stores 10 dimmer laws :

Dimmer law

- linear rms voltage
- linear to 120V
- fluorescent lighting
- linear with 5% preheat level
- square law
- TV
- non-dim (on at 15 %)
- spare / special 1
- spare / special 2
- spare / special 3

Display

- Lin
- 120V
- Fluo
- Preh
- Sqr.
- TV
- OnOf
- Sp.1
- Sp.2
- Sp.3

Notes on the dimmer laws

- a dimmer which is set to the Non-dim (On/Off) law will not dim: the output will be On when the control levels rises above 15 %. The dimmer channel will remain On until the control levels drops below 12 %.
- the 120 V law will give an output varying linearly between Off (0%) and 120 Vrms (100%) for a 220 V mains supply. Please note that even though the rms voltage is reduced by the dimmer, the luminaire is still connected to the 220 V mains network. You must verify that isolation etc. is suitable for connection to a 220 V supply.
- it is recommended to select the 120 V dimmer law in the dimmer, rather than in the lighting control desk.
- when set to the 120 V law, the max. load for that dimmer is $10 \text{ A} \times 120 \text{ V} = 1200 \text{ W}$.
- to measure the output voltage of a dimmer, you need a "true rms" voltmeter. Other Voltmeters will cause false readings.
- three spare positions are reserved for customized dimmer laws, which can be factory-programmed to your wishes.

Application example: if MICROPACKs are used as extension of an existing analogue dimmer system, then the dimmer law of the existing system could be factory-programmed in the new dimmers, so that all dimmers in the system have a similar response.

Selection or reset of the dimmer law, valid for all dimmers

This function is included in Menu 2.

The dimmer law can be selected simultaneously for all dimmers in the unit, by means of a single operation. This will clear any previous individual dimmer law settings. The most frequently used law is linear.

Example : to set all dimmers to Linear:

- select Menu 2, as indicated above
- depress + or - until **Law**
- depress **YES**
- the display shows **All?**
- depress **YES**
- depress + or - until **Lin**
- depress **YES**
- the display returns to the main Menu **Law**

MICROPACK MICRORACK 25

Selection of the dimmer law, per dimmer

This function is included in Menu 2.

The dimmer law can be selected for each dimmer individually, to match the different types of loads that may be connected to a dimmer.

Example : all dimmers are now set to Lin (see example above). You now wish to set No. 2 to On/Off, and No. 5 to Fluo.

- select Menu 2, as indicated above
- depress + or - until
- depress **YES**
- the display shows
- depress +
- the display shows
- depress + until
- depress **YES**
- the display shows the current setting
- depress + or - until
- depress **YES**
- we now proceed with dimmer 5 :
- depress + or - until
- depress **YES**
- the display show the current setting
- depress + or - until
- depress **YES**

Law

All?

Dim 1

Dim 2

Lin

OnOf

dimmer 2 has now been set to **On/Off**.

Dim 5

Lin

Fluo

dimmer 5 has now been set to **Fluo**.

To return to the main Menu:

- depress + until

Law

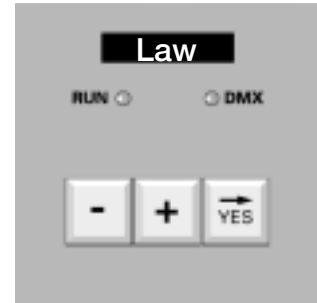

MICROPACK MICRORACK 25

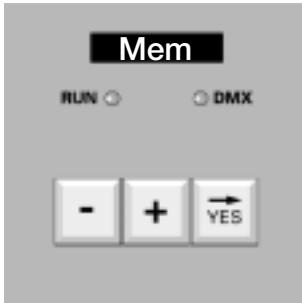

Memorized dimmer cue

Your MICROPACK / MICRORACK 25 can permanently memorize one lighting cue (memory), with individual level settings per dimmer.

To Record the cue

The first way to record the cue, is to use your lighting control desk (DMX and/or Analogue) to set the levels of the dimmers. The Record function of the dimmer will then make a snapshot, and the levels will be stored.

- select Menu 2, as indicated above
- depress + or - until **Mem**
- depress **YES**
- the display shows **Play**
- depress + until **Rec.**
- depress **YES**
- the display shows **ok !** for two seconds to confirm that the dimmer levels were recorded.
- the display returns to the main Menu **Mem**



To edit the cue

You can create a lighting cue directly on the dimmer unit, without a lighting control desk.

You can also modify the lighting cue which is currently stored in your dimmer unit.

You can see the effect of the adjustment that you make: in the Edit mode the lighting levels are visible on stage. In the Edit mode the control inputs (DMX and/or Analogue) are temporarily discarded, they do not influence the dimmer levels.

Example : all the current levels are 0%, and you would like to create a cue which uses three dimmers at different levels:

- dimmer 2 at 20%
 - dimmer 4 at 60%
 - dimmer 5 at 80%
 - dimmers 1, 3 and 6 should remain at 0%
- select Menu 2, as indicated above
 - depress + or - until **Mem**
 - depress **YES**
 - the display shows **Play**
 - depress + until **Edit**
 - depress **YES**
 - the display shows **1:0%** which tells us that in the current cue, the level of dimmer 1 is 0%.
 - depress **YES**
 - the display shows **2:0%** the current level blinks
 - we want to increase the level of dimmer 2 to 20%
 - depress + or - until **2:20**
 - depress **YES**
 - the display shows **3:0%**
 - depress **YES**
 - the display shows **4:0%**
 - we want to bring the level of dimmer 4 to 60%
 - depress + or - until **4:60**
 - depress **YES**
 - the display shows **5:0%**
 - we want to bring the level of dimmer 5 to 80%
 - depress + or - until **5:80**
 - depress **YES**
 - the display shows **6:0%**
 - depress **YES**
 - the display returns to the main Menu **Mem**

MICROPACK MICRORACK 25

To display the contents of the cue

- select Menu 2, as indicated above
- depress + or - until **Mem**
- depress **YES**
- the display shows **Play**
- depress + until **Edit**
- depress **YES**

- the display shows the level for dimmer 1 **1:xx** where xx is the current level
- depress **YES**
- the display shows the level for dimmer 2 **2:xx**
- depress **YES**
- the display shows the level for dimmer 3 **3:xx**
- continue until dimmer 6
- the display shows the level for dimmer 6 **6:xx**
- depress **YES**
- the display returns to the main Menu **Mem**

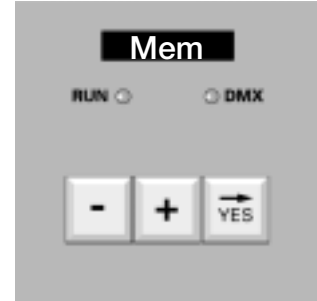

To play-back the cue

This function is included in Menu 2.
The cue stored in memory can be played-back at any moment by means of the Play function. While you play-back the cue, the control inputs (DMX and/or Analogue) are discarded and they do not influence the dimmer levels.

- select Menu 2, as indicated above
- depress + or - until **Mem**
- depress **YES**
- the display shows **Play**
- depress **YES**
- the display shows a sequence **memo playing** to confirm that the cue is played.

This message is continuously displayed, and informs you that the control inputs are temporarily disabled.

To stop play-back and resume normal operation

- depress + or -
- the display returns to the main Menu **Mem**

Automatic play-back of the cue at power-up

If the mains supply was switched off while in the **memo playing** mode, then the dimmer unit will automatically resume that **memo playing** mode when it is switched on again. The **memo playing** message is continuously displayed, and informs you that the control inputs (DMX512 and Analogue) are temporarily disabled.

Application example :

this function is very useful for stand-alone operation without control desk, such as when lighting a display or an exhibition booth. The dimmer unit is set to the Memo Play mode and the user only has to switch the power supply on and off. The dimmer will automatically play the levels stored in the memory.

To stop play-back and resume normal operation

- depress + or -
- the display returns to the main Menu **Mem**



Troubleshooting tools

DMX tester : display the DMX levels

This function is included in Menu 2.

The DMX LED indicator will inform you of the presence of a signal on the DMX512 network.

If a dimmer channel does not appear to give the output level which you expect, then one should verify which control level is actually received by the dimmer.

If these levels are not what you expect, then you should check the control desk: master fader, top limit, dimmer law in the desk,...; and check the Address of your dimmer unit.

If the DMX level is correct, but the dimmer output level is not, then you should also check that the dimmer law in the dimmer is set correctly.

To display the DMX levels

- select Menu 2, as described above
- depress + or - until **D.in**
- depress **YES**
- if the display shows for example **1:69** then dimmer No. 1 receives a level of 69% from the DMX512 control desk.
- depress + or - to review the levels for the six dimmers.
- after dimmer No. 6 the display will return to the main Menu.

DMX! message

This message indicates an error in the DMX signal. Possible causes are :

- start address different from 0; check the control desk's settings
- DMX message contains more than 512 dimmer levels; check the control desk's settings
- one of the data wires (data + or data -) is interrupted; check DMX cables

Analogue input tester : display the Analogue levels

This function is included in Menu 2.

If your dimmer unit is equipped with the Analogue Input (and the Analogue Input is Enabled), then you can display the analogue control levels.

If these levels are not what you expect, then you should check the control desk: master fader, top limit, dimmer law in the desk,...

If the analogue control level is correct, but the dimmer output level is not, then you should also check that the dimmer law in the dimmer unit is correct.

To display the Analogue levels

- select Menu 2, as described above
- depress + or - until **A.in**
- depress **YES**
- if the display shows for example **1:56** then dimmer No. 1 receives a level of 56% from the analogue control desk.
- depress + or - to review the levels for the six / twelve dimmers.
- after dimmer No. 6 the display will return to the main Menu.

MICROPACK

MICRORACK 25

Warning messages (important !)

Under special circumstances the display will show flashing warning messages. All actions inside the dimmer unit should only be performed by qualified personnel.

400 V

This warns you that an excessive voltage is applied to at least one of the phases. The unit has shut itself down, no dimmer will operate.

Actions to take

- **immediately disconnect the MICROPACK / MICRORACK 25 from the mains**
Note: if this action is taken quickly (typically less than one minute), the dimmer will reset itself automatically and will be ready to function immediately after the proper mains supply is restored
- verify that the Neutral conductor is properly connected
- verify the supply voltage between each of the Phases and Neutral. It should be in the range 198 V to 264 V ($230\text{ V} \pm 14\%$)

Two typical examples of cabling errors in three-phase systems are

- Error n°1: inversion between neutral and a phase (example: when L3 and N are inverted) the voltage L3-to-neutral will be normal $\pm 230\text{ V}$, and the other two phase-to-neutral voltages will be $\pm 400\text{ V}$
 - Error n°2: the neutral is disconnected
- Such situations and errors are dangerous ! Always refer to a qualified electrician.

Temp

The MICROPACK and MICRORACK 25 are equipped with thermal protection circuitry. The flashing **Temp** message indicates that the internal temperature is rising and that the microprocessor is gradually reducing the level of all dimmers.

Please check

- room temperature
 - fan(s)
 - air inlet grilles in the socket panel
 - exhaust grille and fan in the front panel
 - side panels, which also act as heatsinks
- Please refer to the Maintenance chapter, section "Over-temperature, gradual shutdown".

Run and the Display and DMX are unlit

The microprocessor is not operational. This situation can be caused by an unacceptable (too low or too high) supply voltage on phase L1. Immediately disconnect the MICROPACK from the mains. Please refer to the 400 V Warning message above. Check internal fuse F2 (phase L1) on the Microprocessor board (PCB 1337, PCB 1410). Please refer to the Troubleshooting chapter, Power section.

Fan

The Fan message warns you of problems with the fan(s). Forced ventilation is essential for continuous and reliable operation of your MICROPACK at high loads. To extend the service life of the fan, and to reduce acoustic fan noise, the microprocessor will monitor and control the operation of the fan. Fan speed control: the fan will for example stop when the unit is cool, and only one dimmer is operational, and at a low dimmer level. This is clearly visible during the Auto test mode (chaser).

No L2 and No L3

Missing phases: No (or low) voltage on phase L2, No (or low) voltage on phase L3. Please refer to the Troubleshooting charts at the end of the Manual. Verify the mains supply. If the mains supply is OK, disconnect the dimmer unit from the mains and check internal fuses F1 (phase L3) and F3 (phase L2).

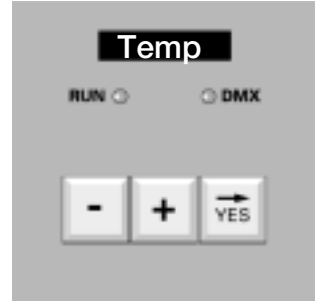



Maintenance functions

Software version

The software version is displayed at power-up, or after a Reset.
Example: for software version 1.02, the display will show V102.

Maintenance menu - Menu 3

The Maintenance menu, Menu 3, is intended for maintenance engineers only. Its functions are not required for day-to-day use.

Functions of Menu 3 :

- all functions of Menu 2, and
- automatic self-test routines
- Analogue Input enable/disable
- various Clear functions
- setting of digital smoothing
- service test of thermostat

Analogue input mode : enable / disable

This function is included in the Maintenance Menu, Menu 3.

- if your dimmer is equipped with the Analogue Input, then this should be set to Enable (On).
- if your dimmer is not equipped with the Analogue Input, then it must be set to Disable (Off).

The installation procedure of the Analogue Input Kit is described in a separate paragraph.

WARNING: the Analogue Inputs are disabled by the Clear All function (see next page).

To Enable the Analogue Inputs :

- select Menu 3, as described above
- depress + or - until **AinM**
- depress **YES**
- depress + or - until **On**
- depress **YES**
- the display returns to the main Menu **AinM**

To Disable the Analogue Inputs :

- select Menu 3, as described above
- depress + or - until **AinM**
- depress **YES**
- depress + or - until **Off**
- depress **YES**
- the display returns to the main Menu **AinM**

To clear the memorized cue

This function is included in the Maintenance Menu, Menu 3.

This function sets all levels in the cue to 0%.

- select Menu 3, as described above
- depress + or - until **Clr.**
- depress **YES**
- depress + or - until **Cue**
- the display shows **ok !**
for two seconds to confirm that the dimmer levels were reset to 0%.

MICROPACK

MICRORACK 25

To clear and reset more parameters

This function is included in the Maintenance Menu, Menu 3.

This function will reset the parameters which are most frequently re-programmed.

We suggest you use this function e.g. after a rental job.

The following parameters are reset to their default value :

- Address 1 (dimmers have DMX address 1 to 6 or 12)
- Law all dimmers Linear law
- Mem all dimmers at 0% in the cue
- Test level 70%

- select Menu 3, as described above
- depress + or - until **Clr.**
- depress **YES**
- depress + or - until **More**
- the display shows **ok!** for two seconds to confirm the reset.
- the display returns to the main Menu **Clr.**



To clear and reset all parameters

This function is included in the Maintenance Menu, Menu 3.

This function should be used with care as it will reset all the parameters to their factory default value:

- Address 1 (dimmers have DMX address 1 to 6 or 12)
 - Law all dimmers Lin dimmer law
 - Mem all dimmers at 0% in the cue
 - Frequency 50 Hz
 - Smoothing normal digital smoothing
 - Analogue analogue inputs disabled
- Note: if your dimmer is equipped with the Analogue Inputs, you must Enable them after the Clear All reset. See Menu 3, AinM function.
- Ther The1 for MICROPACK, The2 for MICRORACK 25
 - Menu Menu 1

- select Menu 3, as described above
- depress + or - until **Clr.**
- depress **YES**
- depress + or - until **All**
- the display shows **ok!** for two seconds to confirm the reset.
- the display returns to the main Menu **Clr.**

To change the smoothing grade, for all dimmers

This function is included in the Maintenance Menu, Menu 3.

The factory- and default setting for the digital smoothing is Normal.

- select Menu 3, as described above
- depress + or - until **Filt**
- depress **YES**
- depress + or - until **norm**
- depress **YES**
- the display returns to the main Menu **Filt**

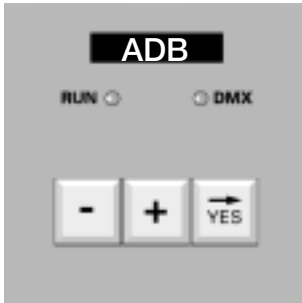

ADB

This function is included in Menu 3. This menu is reserved for maintenance and factory production tests. Please note that some of these tests will clear and reset all parameters.

Ther

This function is included in the Maintenance Menu, Menu 3.

This menu is reserved for factory tests or special applications. Do not modify the factory default setting, which is The1 for the MICROPACK and The2 for the MICRORACK 25.

- select Menu 3, as described above
- depress + or - until **Ther**
- depress **YES**
- depress + or - until **The1 (or The2)**
- depress **YES**
- the display returns to the main Menu **Ther**

Fan Speed Control

Please refer to the **Fan** message in "Warning Messages"

MICROPACK MICRORACK 25

Putting into Operation

Power section

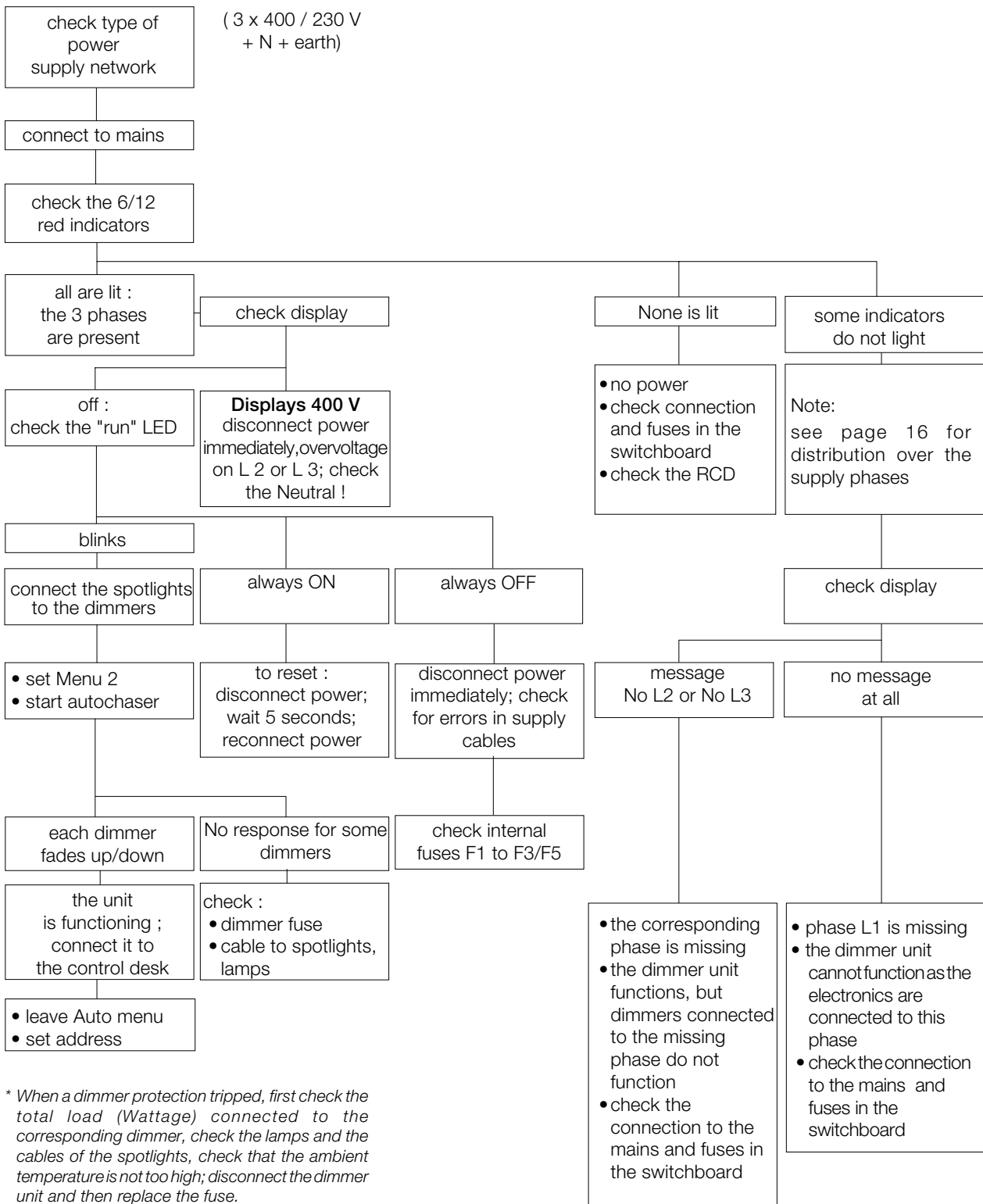

Putting into Operation

Operating section

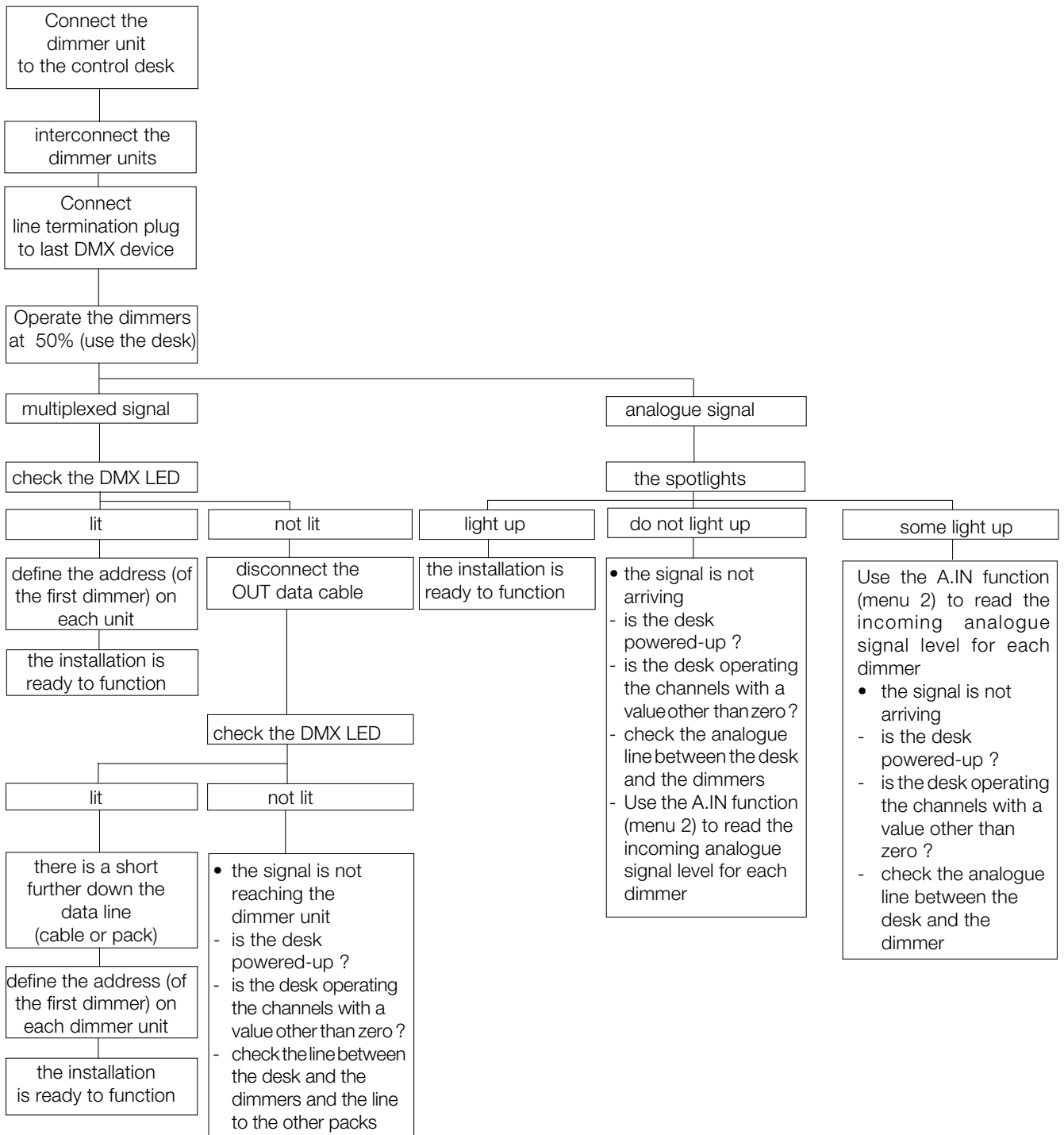

MICROPACK MICRORACK 25

PCB 1337 Microprocessor (CPU) board

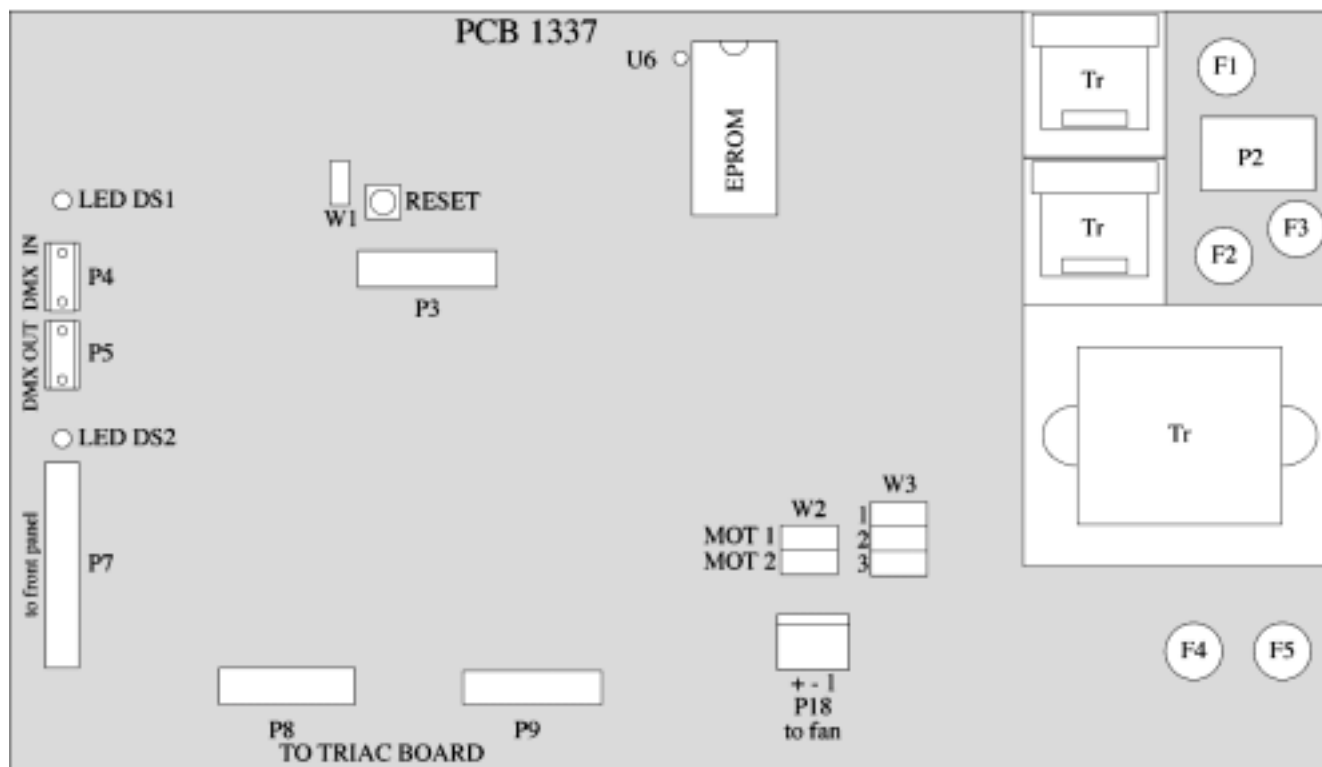

Function of the five fuses

- | | | | |
|-----------|--|---------|-------------|
| • fuse F1 | phase L3 (mains reference) | Part N° | 6130.07.105 |
| • fuse F2 | phase L1 (supply of microprocessor electronics, and mains reference) | Part N° | 6130.07.130 |
| • fuse F3 | phase L2 (mains reference) | Part N° | 6130.07.105 |
| • fuse F4 | phase L1 (mains reference, transformer output) | Part N° | 6130.12.130 |
| • fuse F5 | phase L1 (aux. supply, transformer output) | Part N° | 6130.12.130 |

LED indicators

- DS1 (green) +5V aux
- DS2 (green) +5V

Jumper position W1

- W1: jumper must be present

MICROPACK MICRORACK 25

PCB 1410 Microprocessor (CPU) board

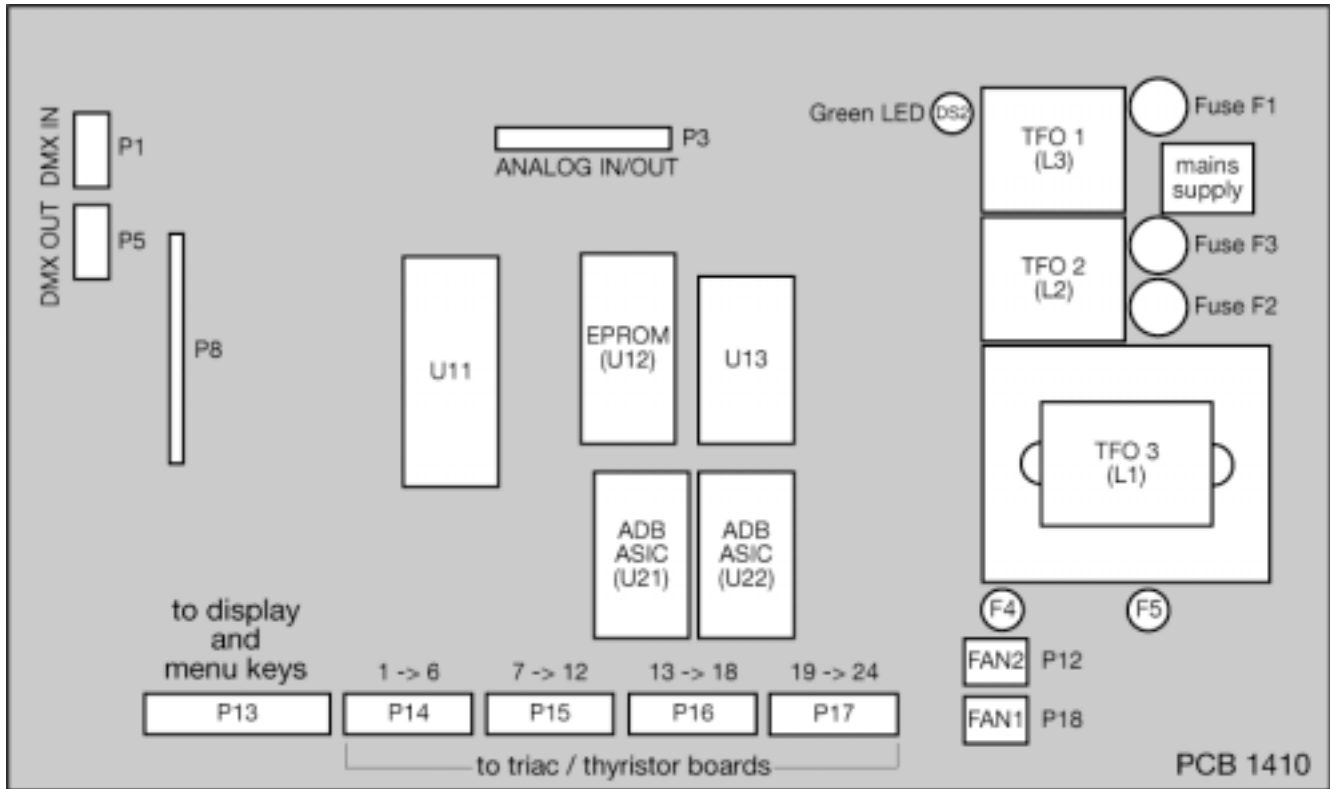

Function of the five fuses

- fuse F1 phase L3 (mains reference)
- fuse F2 phase L1 (supply of microprocessor electronics, and mains reference)
- fuse F3 phase L2 (mains reference)
- fuse F4 not serviceable by user
- fuse F5 not serviceable by user

Part N° 6130.07.105
 Part N° 6130.07.130
 Part N° 6130.07.105

LED indicator

- DS2 (green) +5V

MICROPACK MICRORACK 25

Miscellaneous

Protection against accidental 400 V

Warning : always check the mains voltage before you connect power to electrical equipment. If excessive voltages are applied, the internal protection circuitry will disable the dimmer unit.

To restore normal operation:

- disconnect the dimmer unit from the mains
- remove the top cover, see sketch in "Supply Connections" chapter
- check the fuses (5 x 20 mm) - see sketch "Microprocessor board" - replace blown fuses by suitable type only
- close the unit; check presence of special washers
- verify the power source; possible cabling errors include inversion between phase and Neutral, or disconnected Neutral
- restore power to the dimmer only when you are confident that the power source is satisfactory

400 V Message

This warns you that an excessive voltage is applied to at least one of the phases. The unit has shut itself down, no dimmer will operate.

ACTIONS TO TAKE: see Warning Messages- 400 V

Loss of DMX signal - time-out

Should the DMX control signal disappear, then the microprocessor will keep the last levels indefinitely. Dimmer levels can always be brought back to "Off"

- by restoring the DMX line
- or by disconnecting the power to the MICROPACK
- or by entering the dimmer test mode (see "Test") and setting a "0 %" level

DMX! message

See "Troubleshooting tools" on page 25.

MICROPACK

MICRORACK 25

Microprocessor reset

The "Run" indicator on the front panel flashes at a rate of once per second, if the microprocessor is operational. Should the indicator stop blinking, then you can Reset the microprocessor by disconnecting the power supply to the dimmer.

Use the supply isolator, the RCD or the MCB; never use the supply plug!

Over-temperature - gradual shutdown

Your dimmer unit is equipped with a temperature monitoring system. Should the internal temperature rise, then the display will show a flashing message (**TEMP**).

Your dimmer unit is rated for continuous duty, so a **TEMP** warning is an indication of faulty operation or use.

Please verify :

- the room temperature (35°C max.)
- that the air intake and exhaust apertures are not obstructed
- that the air intake is not influenced by the warm air exhausted by other equipment
- that the fan is still operational
- that no dimmer is loaded to more than 10 A (2.200 W at 220 V, or 2.400 W at 240 V)

Reduced dimmer levels or loads will reduce the internal heat dissipation.

If the internal temperature remains too high for several minutes, then a **TEMP** message will flash and the unit will protect itself by a gradual shutdown:

- first all dimmer levels will be slightly reduced
- followed later by further reductions of all dimmer levels
- normal operation is automatically restored when a safe temperature is reached, and after reset

When installing dimmers in 19" racks or touring racks, check that the rear panel of the rack does not block airflow. Provide sufficiently large air openings ! Avoid recirculating warm air in the rack or flight-case.

Internal fuses

If the dimmer indicators are lit, but the front panel LED's nor the display light up, then you should check the fuses for the control electronics. These fuses are independent of the dimmer protections on the front panel. They can easily be reached (qualified personnel only !):

- disconnect the dimmer unit from the mains
- remove the top cover, see sketch in "Supply Connection"
- check the (5 x 20 mm) F1 to F3/F5 - see sketch "Microprocessor board"
- replace fuses, if necessary; use suitable fuses only !
- close the cover; check the presence of the special washers

The use of incorrect fuses is dangerous, may cause permanent damage, and will void warranty.

Characteristics

MICROPACK and MICRORACK 25 are professional equipment, and should always be used in accordance with applicable safety regulations.

Electrical characteristics

Control electronics :

fully digital, microprocessor controlled

Ratings :

dimmers are rated for continuous duty

Operating temperature range :

+ 5 °C to 35 °C; relative humidity max. 95%, non-condensing; altitude < 1000 m

Supply system :

3NPE, 400 V, 50 Hz and 60 Hz (TN-S system, Neutral directly connected to Earth; 230 V between phase and Neutral). Reduced-size N conductor is not allowed. Single-phase operation is possible (single-pole protected).

Supply voltage range :

198 V to 264 V (230 V \pm 14%)

Accidental 400V supply :

internal protection circuitry will disable the dimmers

Rated supply current :

- for Star three-phase 3NPE supply : 20 A per phase (MICROPACK)
- for single-phase supply : 60 A (MICROPACK)
- for Star three-phase 3NPE supply : 40 A per phase (MICRORACK 25)

Dimmer protection :

- MICROPACK: MCB single pole 10 A curve C, 6 kA and 10 x 38 mm (100 kA) for 1P + N option
- MICRORACK 25: single-pole fuses, 10 x 38 mm, HRC (100 kA), gL, gG 8A or MCB single pole 10A curve C

Fuseholders for 10 x 38 mm :

- are equipped with a slot for a spare fuse

Residual Current Device:

when a RCD is required (e.g. TT and IT supply systems, or local regulations), this should be integrated in the supply installation.

Control inputs:

- DMX512/1990 (USITT digital multiplex standard)
- optional analogue 0/+10V or 0/+370 μ A (internal conversion)
- simultaneous DMX and analogue inputs : Highest Takes Precedence

DMX control signal failure :

- the last valid DMX message will be kept indefinitely

DMX address :

- setting of the DMX-address of the first dimmer by means of Menu

Dimmer laws (selectable per dimmer) :

- linear rms voltage, linear to 120 V, fluorescent lighting, linear with 5% preheat level, square law, TV, non-dim (on at 15 %), and 3 spare / special

Front panel indicators :

- "channel fuse is OK" per dimmer
- presence of DMX512 control signal
- microprocessor operational
- fault messages (display)

Dimmer test functions :

- automatic chaser at 70%
- one dimmer at any level
- lighting cue without a desk
- self-test (internal)

Response time :

- DMX : better than 35 ms
- analogue : better than 40 ms
- dimmer precision : 4000 dimmer levels

Efficiency at rated load :

better than 98 %

Dissipation at rated load :

less than 40 W per 10 A dimmer

DC component in output voltage :

below 1 V in rated load range

Minimum load :

25 W for a 10 A dimmer (typical)

Types of load :

suitable for resistive and inductive loads, such as tungsten lamps, low voltage halogen lamps with a suitable transformer, fluorescent lamps with suitable ballast.

Colour code for supply cable (if applicable)

Brown and/or black : phases L1, L2, L3
Blue : Neutral
Yellow/green : Earth

Safety standards

- EN60204
- EN60950

MICROPACK

MICRORACK 25

Mechanical characteristics

MICROPACK Portable

Dimensions A x B x C	(mm)	360 x 445 x 142
Net Weight	(kg)	14
Packing	(mm)	460 x 595 x 245
Gross Weight	(kg)	16

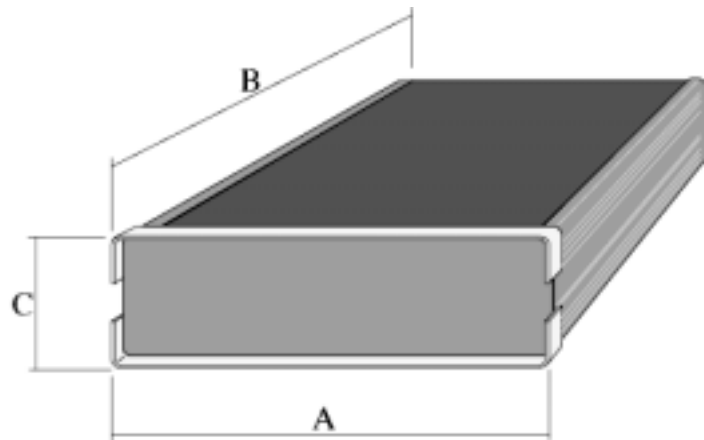

MICROPACK with 19" rack mounting brackets

Dimensions A x B x C	(mm)	484 x 445 x 133 (3U)
Net Weight	(kg)	14
Packing	(mm)	460 x 595 x 245
Gross Weight	(kg)	16

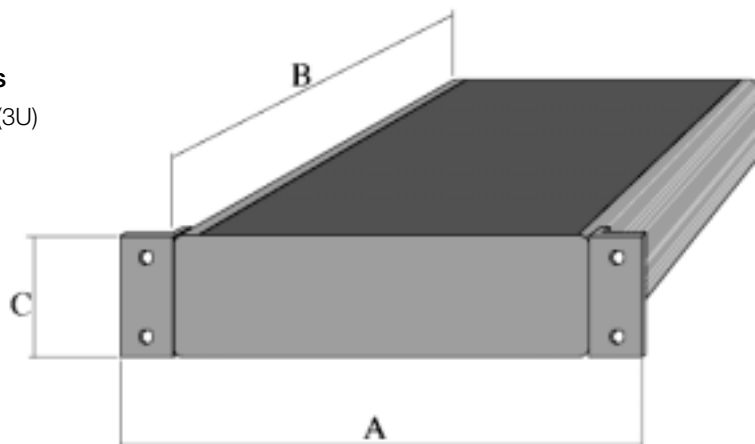

Note: MICROPACK must be supported when mounted in a 19" rack

MICRORACK 25

Dimensions A x B x C	(mm)	484 x 500 x 133 (3U)
Net Weight	(kg)	17
Packing	(mm)	540 x 595 x 245
Gross Weight	(kg)	19

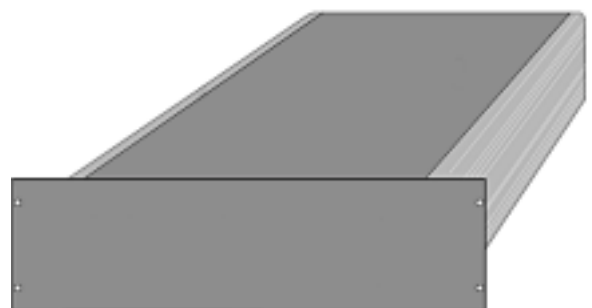

Note: MICRORACK and MICROPACK 25 must be supported when mounted in a 19" rack

Installation of the Analogue Inputs kit

If your MICROPACK / MICRORACK 25 was not factory-equipped with the Analogue Inputs, you can upgrade it by means of a kit.

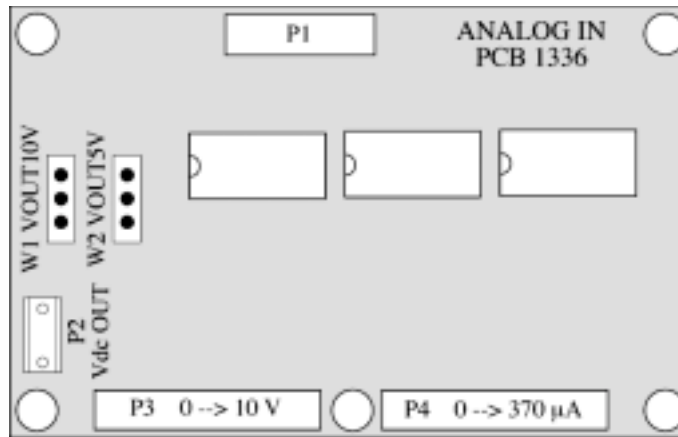

PCB 1336
Analog Input
board (optional)

Contents of the analogue input kit

- analogue input board PCB1336.x. It exists in three versions:
 - PCB1336.1 the partially equipped version for 6 inputs
 - PCB1336.2 the partially equipped version for 12 inputs
 - PCB1336.3 the fully equipped version for 24 inputs

For the connection of remote control buttons controlling the memories, the 24-input version is required.

- five plastic spacers
- long ribbon-cable, for use in EURORACK 60
- short ribbon-cable, for use in MICROPACK, MICRORACK 25, MEMOPACK, MEMORACK
- set of nuts etc. to install the SubD-25
- a SubD-25M plug for cable

MICROPACK MICRORACK 25

Instructions

- disconnect the dimmer unit from the mains
- remove the top cover; see sketch in “Product description: Supply terminals”
- the analogue input board PCB 1336 is to be mounted onto the microprocessor board PCB1410. See enclosed drawings. Please note the 20-pin connector and the five holes for the spacers.
- install the five plastic spacers on the CPU board PCB 1410
Note : on some batches, the holes in PCB 1410 were slightly too small. If this is the case, do not force. Slightly adjust one end of the plastic spacers with a sharp knife.
- install PCB 1336 by mating the 20-pin connector, and the five plastic spacers
- P1 on PCB 1336 (Analogue Input board) mates with P3 of PCB1337 / PCB1410 (Microprocessor CPU board)
- for 0/+10 V operation: connect the ribbon cable (25 conductors) with the front panel Analogue receptacle (DB-25-S) to P3 on PCB 1336 (Analogue Input board)
- 0/+370 μ A operation: connect the ribbon cable (25 conductors) with the front panel Analogue receptacle (DB-25-S) to P4 on PCB 1336 (Analogue Input board)
- secure the ribbon cable away from the filter chokes and power wiring
- close the cover (carefully replace the special washers !!!)
- enable the Analogue Inputs, by means of the AinM function in Menu 3

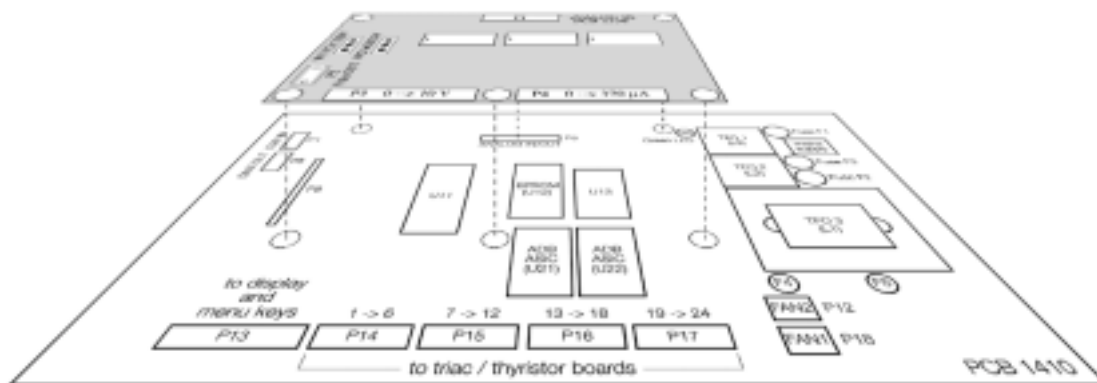

Enabling of the analogue inputs

After the Analogue Input Board PCB 1336 has been installed, you must enable them by means of the menu. Your setting will stay memorized after you switch power off : the setting is stored in an EPROM.

Summary :

Connect the dimmer unit to the mains supply.

Menu ?	YES
Men 3?	YES YES YES
A In M?	YES
On	YES

Then select the required operating mode (Muted; analogue input 0/10V; Special 1) Confirm by **YES**.

As a precaution, you should then lock access to the menus :

Menu Level?	YES
Level 0	YES

MICROPACK

MICRORACK 25

Maintenance

Fuses

The six or twelve dimmer fuses are placed on the front panel.

The internal fuses are accessible by removing the top cover (see sketch "Supply Terminals").

Always disconnect the power before you open the dimmer unit or replace a fuse!

Switch power off by means of the supply isolator, supply MCB or supply RCD.

Then disconnect the supply plug.

Always use fuses of the same type, size, current rating, fusing value (I_{2t} value) and fault current rating as the originals. Contact your supplier for spare parts.

List of Accessories and Spare Parts

Always use original spare parts, do not use substitutes. The original components were selected to achieve the performance and reliability you expect of your equipment.

DMX cables

- 1145.12.775 DMX512 data cable with XLR 5 connectors (2 m)
- 1145.12.780 DMX512 data cable with XLR 5 connectors (5 m)
- 1145.12.785 DMX512 data cable with XLR 5 connectors (10 m)

Connectors, sockets

- 6117.15.110 XLR 5 M plug, for cable mounting, for DMX512
- 6117.15.120 XLR 5 F receptacle, for cable mounting, for DMX512
- 6117.47.012 DB25-P plug, for cable mounting, for Analogue Inputs
- 6117.47.013 cover for DB25-P plug
- 1112.00.060 output cable kit for MICRORACK 25 with AMP outputs (2 AMP connectors, factory-crimped cables, length 1.5 m)
- 6113.34.003 output socket, double Schuko
- 6113.34.010 output socket, double CEBEC/NF
- 6113.34.005 output socket, triple Swiss
- 6113.53.105 output socket, CEE16(P17)
- 6113.34.020 output socket, UK 15A (round pins)

Fuses, fuse-holders (must be ordered in multiples of 10 pcs)

- 6130.45.150 fuse for MICROPACK (6 x 32 mm, High Rupturing Capacity 10kA, 8A, curve gL, gG)
- 6130.45.170 fuse for MICRORACK 25 (10 x 38 mm, High Rupturing Capacity 100kA, 8A)
- 6130.07.105 fuse 0,08 A M on CPU board PCB 1410
- 6130.07.130 fuse 0,1 A T on CPU board PCB 1410
- 6130.99.138 fuse-holder for MICROPACK, including cap (6 x 32 mm)
- 6132.00.095 fuse-holder for MICRORACK 25, 1P+N versions (10 x 38 mm)
- 6130.99.515 fuse-holder for CPU board and MICROPACK, including cap
- 6150.90.101 MCB 10 A curve C

Boards

Please consult your distributor.

Provide him the full Product Reference (1DB ... or 1DH...) and the serial number. You'll find them on the Identificate Label.

Miscellaneous

- 1112.07.000 Analogue Input kit (PCB 1336.1, ribbon cable,...) for MICROPACK (6 inputs)
- 1112.07.010 Analogue Input kit (PCB 1336.2, ribbon cable,...) for MICRORACK 25 (12 inputs) + 1136.3 (24 inputs)
- 7074.10.035 fan for MICROPACK, MICRORACK 25
- single-phase conversion kit for MICROPACK
- rack-mounting kit (brackets for 19" rack) for MICROPACK 25

Warning

Lethal voltages are used in this equipment. Refer servicing to trained personnel.

Power must be disconnected before a fuse is removed.

Power must be disconnected before the cover is removed.

MICROPACK MICRORACK 25

DATA CABLE

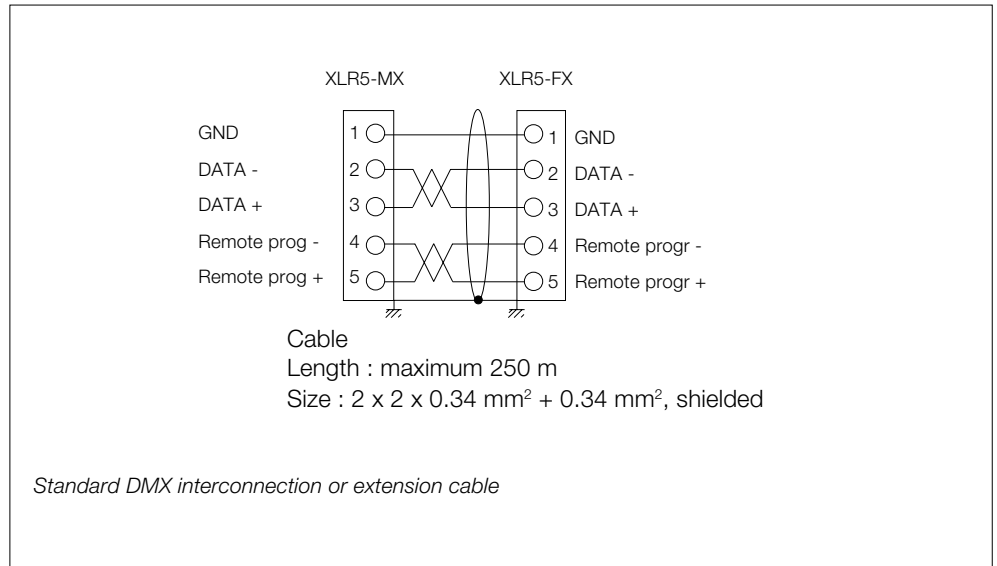

TERMINATING RESISTOR

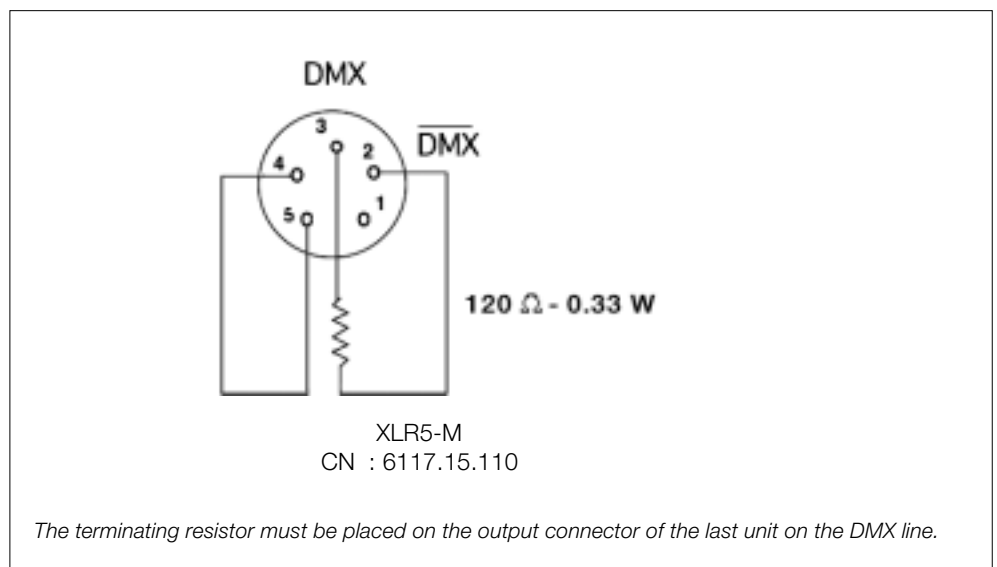

MICROPACK MICRORACK 25

DMX Data Connections



XLR5 - M

Pin	Signal
1	GND
2	DMX data -
3	DMX data +
4	Spare / remote programming -
5	Spare / remote programming +



XLR5 - F

Pin	Signal
1	GND
2	DMX data -
3	DMX data +
4	Spare / remote programming -
5	Spare / remote programming +



IEEE-488 (DDK)

Pin	Signal
1	GND
2	DMX data -
3	DMX data +
4	Spare / remote programming -
5	Spare / remote programming +

MICROPACK MICRORACK 25

Dimmer Output Connections

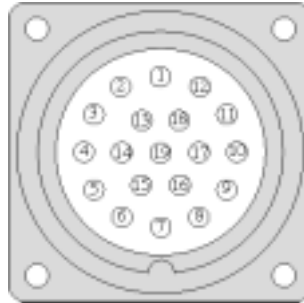

SOCAPEX or compatible

Pin	Phase	Channel
1	L	1
2	N	
3	L	2
4	N	
5	L	3
6	N	
7	L	4
8	N	
9	L	5
10	N	
11	L	6
12	N	
13		PE
14		
15		
16		
17		
18		
19		

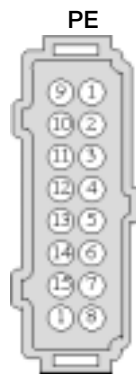

HARTING

Pin	Phase	Channel
1	L	1
2	L	2
3	L	3
4	L	4
5	L	5
6	L	6
7	NC	
8	NC	
9	N	1
10	N	2
11	N	3
12	N	4
13	N	5
14	N	6
15	NC	
16	NC	

Dimmer Supply Connections

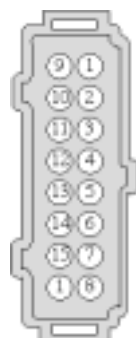

HARTING POWER

Pin	Phase
1	L1
2	L2
3	L3
4	N

MICROPACK

MICRORACK 25

Dimmer Output Connections

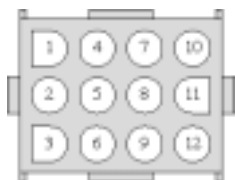

AMP for
MICRORACK
(2.3kW) and
MEMORACK (3kW)

Connector 1			Connector 2		
Pin	Phase	Channel	Pin	Phase	Channel
1	L	1	1	L	7
2	N*		2	N*	
3	L	2	3	L	8
4	N*		4	N*	
5	L	3	5	L	9
6	N*		6	N*	
7	L	4	7	L	10
8	N*		8	N*	
9	L	5	9	L	11
10	N*		10	N*	
11	L	6	11	L	12
12	N*		12	N*	

* Only for 1P+N versions
Factory - crimped "AMP cable kits" are available.

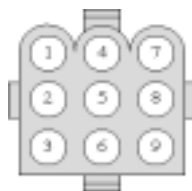

AMP for
MEMORACK (5 kW)

Connector 1			Connector 2		
Pin	Phase	Channel	Pin	Phase	Channel
1	L	1	1	L	4
2	N*		2	N*	
3	L	2	3	L	5
4	N*		4	N*	
5	L	3	5	L	6
6	N*		6	N*	
7	-		7	-	
8	-		8	-	
9	-		9	-	

* Only for 1P+N versions
Factory - crimped "3AMP cable kits" are available.

Table of Contents

Generalities - Safety	2
Description	3
Weight and dimensions	3
Main Features	3
Technical Specifications	3
Architectural Applications	3
Front Panel	4
Indicators	4
Control protocols	4
Power Supply Connection	4
Mains Supply	4
Protections	4
Option	4
Standard Outlets Panels	5
MICROPACK	5
MICRORACK 25	5
Output wiring	5
Product Description	6
Digital dimmers	6
Ratings	7
Loads	7
Packaging : Portable, Rack-Mount	7
Rubber feet	7
Cooling	7
Supply connections	8
Protection on the supply side	8
Supply terminals	8
How to remove the top cover	8
Supply cable	9
Operation on a Star system (3 x 400 V + N + Earth)	9
Single-phase conversion kit	9
Control Connections	10
DMX512/1990	10
DMX512 network	10
Termination of the DMX line	10
Dimmer Address	10
The DMX512 network	10
Opto-isolation	10
Example	15
Internal setting for Analogue Inputs	15
Analogue Inputs : selection 0/+10 V or 0/370 μ A	15
Front-panel Controls	16
Fuse and Power Indicators	16
Phase Distribution	16
Status Indicators	16

MICROPACK

MICRORACK 25

MENU	17
Principle of operation	17
Simplicity tailored to your needs	17
Menu 1	17
Menu 2	17
Menu 3	17
Default display	17
“Hidden” items are not disabled	18
How to select the Menu level	18
Non-volatile memory	18
Dimmer address	19
The DMX address	19
Setting of the dimmer address	19
Dimmer test	19
Auto dimmer test - chaser	19
To start the chaser	19
Individual dimmer test	20
To end the Test mode and to restore normal operation	20
Dimmer law	21
Selection or reset of the dimmer law, valid for all dimmers	21
Selection of the dimmer law, per dimmer	22
Memorized dimmer cue	23
To Record the cue	23
To edit the cue	23
To display the contents of the cue	24
To play-back the cue	24
To stop play-back and resume normal operation	24
Automatic play-back of the cue at power-up	24
To stop play-back and resume normal operation	24
Troubleshooting tools	25
DMX tester : display the DMX levels	25
DMX! message	25
To display the DMX levels	25
Analogue input tester : display the Analogue levels	25
To display the Analogue levels	25
Warning messages (important !)	26
400 V	26
Temp	26
Run and the Display and DMX are unlit	26
Fan	26
No L2 and No L3	26
Maintenance functions	27
Software version	27
Maintenance menu - Menu 3	27
Analogue input mode : enable / disable	27
To Enable the Analogue Inputs :	27
To Disable the Analogue Inputs :	27
To clear the memorized cue	27
To clear and reset more parameters	28
To clear and reset all parameters	28
To change the smoothing grade, for all dimmers	28
ADB	29
Ther	29
Fan Speed Control	29

MICROPACK MICRORACK 25

Putting into Operation	30
Power section	30
Operating section	31
PCB 1337 Microprocessor (CPU) board	32
Function of the five fuses	32
LED indicators	32
Jumper position W1	32
PCB 1410 Microprocessor (CPU) board	33
Miscellaneous	35
Protection against accidental 400 V	35
To restore normal operation:	35
400 V Message	35
Loss of DMX signal - time-out	35
Microprocessor reset	36
Over-temperature - gradual shutdown	36
Internal fuses	36
Characteristics	37
Electrical characteristics	37
Control electronics	37
Ratings	37
Operating temperature range	37
Supply system	37
Supply voltage range	37
Accidental 400V supply	37
Rated supply current	37
Dimmer protection	37
Residual Current Device	37
Control inputs	37
DMX control signal failure	37
DMX address	37
Dimmer laws (selectable per dimmer)	37
Front panel indicators	37
Dimmer test functions	37
Response time	37
Power semiconductors	37
Efficiency at rated load	37
Dissipation at rated load	37
DC component in output voltage	37
Minimum load	37
Types of load	37
Fault current rating	37
Colour code for supply cable (if applicable)	37
Safety standards	37
Mechanical characteristics	38
MICROPACK Portable	38
MICROPACK with 19" rack mounting brackets	38
MICRORACK	38
Installation of the Analogue Inputs kit	39
Contents of the analogue inputs kit	39
Instructions	40
Enabling of the analogue inputs	41

MICROPACK

MICRORACK 25

Maintenance	42
Fuses	42
List of Accessories and Spare Parts	42
DMX cables	42
Connectors, sockets	42
Fuses, fuse-holders	42
Boards	42
Miscellaneous	42
Drawings	43

ADB - Your Partner for Light

Belgium **N.V. ADB-TTV Technologies S.A.**

(Group Headquarters) Leuvensesteenweg 585, B-1930 Zaventem
Tel : 32.2.709.32.11, Fax : 32.2.709.32.80, E-Mail : adb@adblighting.com

Deutschland **ADB GmbH**

Boschstrasse 3, D-61239 Ober-Mörlen
Tel : 49.6002.93.933.0, Fax : 49.6002.93.933.33, E-Mail : info@adblighting.de

France **ADB S.A.S.**

Sales Office: 168/170, boulevard Camélinat F-92240 Malakoff
Tel : 33.1.41.17.48.50, Fax : 33.1.42.53.54.76, E-Mail : adb.fr@adblighting.com

Factory & Group Logistics Centre: Zone industrielle Rouvroy F-02100 Saint-Quentin
Tel : 33.3.23.06.35.70, Fax : 33.3.23.67.66.56, E-Mail : adb.fr@adblighting.com

www.adblighting.com

ADB
Lighting Technologies

M-3013-E-07J Subject to modifications